



**TB3 Tender Body Pack  
LMS/BR Stanier/Ivatt  
4000 Gallon  
Part Welded Sides**

Components required to turn this body pack into a complete tender:

TC3            7'6" x 7'6" tender chassis  
TF2 or 3      Tender frame kit  
3 axles 4'3" Stanier tender wheels (WH35)

This body pack is intended for use with our tender frame kits TF2 or TF3, but can also be used for scratchbuilding or to improve an RTR tender.

This development of the familiar 4000 gallon tender had a welded joint between the water tank top and the tender sides and rear. It was introduced from 1946 and allocated to Black 5s built from that date. The familiar tubular air vent pipes were abandoned in favour of a fabrication attached to the rear of the coal bulkhead.

The underframe also saw modifications. Water sieve boxes were fitted, and the spring dampers shortened (TF2). Those locomotives fitted with either Timken or Skefko roller bearings had tenders equipped similarly (TF3).

A listing showing the types of tender first allocated to all the Stanier/Ivatt Black 5 locomotives is available from this product's page on the Wizard Models website.

Parts list - Etchings

- |                      |                                  |
|----------------------|----------------------------------|
| 1. Front bulkhead    | 8. Nearside bunker side          |
| 2. Tank rear         | 9. Offside bunker side           |
| 3. Tank rear overlay | 10. Front platform inner support |
| 4. Sides             | 11. Front platform               |
| 5. Tank top          | 12. Lifting rings                |
| 6. Bunker base       | 13. Lifting ring bases           |
| 7. Rear bulkhead     |                                  |

Parts list - Castings etc.

- |              |                  |                    |
|--------------|------------------|--------------------|
| Tender front | Tank filler      | Handrail knobs (6) |
| Water gauge  | Fire iron tunnel | Handrail wire (2)  |
| Dome         | Tank vents (2)   |                    |

**Assembly Sequence**

Note: Make all folds with the half-etch to the inside of the fold unless stated otherwise. The instructions assume that the body will be built onto the tender base from our frame kit TF2 or TF3, which should be completed up to step (8) in those instructions. It is advisable to add whitemetal castings to both the frames and superstructure only when all hard soldering of etched parts has been completed.

1. Fold up and solder the front bulkhead etch (1), locating to the tender base by the tabs on its lower edge. Check that it is square to the frame in all directions. You may

need to file a small notch each side of the base to ensure clearance from the flanges of the front wheels.

2. Fold out the step treads from the tank rear (2) then fold up and solder this to the tender base, tack soldering at the sides only. Again check for squareness and when satisfied locate the tank rear overlay (3) by placing its lower edge onto the tank base first, then locating the step treads through the slots in the overlay and lastly pressing the overlay tight against the tank rear. Complete the soldering of these items, then file back the vertical edges flush with the tank rear.
3. Check the fit of the tender sides against the front bulkhead. You may find the top bend needs easing slightly for a perfect fit. Before soldering the sides in place, fold up the front platform (11) and ensure that it will fit between the front edges of the sides - it may be necessary to ease the front bends slightly to achieve this. When satisfied, locate the tabs along the bottom edges of the sides into the slots in the tender base and solder in position (sketch 1).
4. If you wish to model the coal bunker fully, fold up the tank top (5) as per the sketch - note that the front bend is made with the half-etch to the outside. Slide the tank top into position - the rear end rests on the top return of the tank rear and the front on the lower edge of the cut-out in the front bulkhead, with the intermediate supports resting on the tank base. When satisfied, solder in position (sketches 3 & 5). Alternatively, if you intend to model the tender coaled up simply bend down the intermediate supports only. In this case the front of the tank top is supported by the horizontal return of the front bulkhead. Again, slide into position and solder (sketch 2).
5. Fold the bunker base (6) to the angle shown in the sketch and fit in position, but do not solder it yet. Now locate the rear bulkhead (7) in place on the tank top and hold it tight against the top fold of the bunker base. If necessary, adjust the angle of the fold until the rear bulkhead is vertical then solder both parts in place (sketch 3).
6. If you have decided to model the coal bunker fully, locate and solder in place the nearside bunker side (8). Bend the top of the offside bunker side (9) so that when in position with the top touching the tender side, the top is approximately horizontal (sketch 4). When satisfied, solder in place. If the bunker is not to be fully modelled discard part 9 and modify the nearside bunker side (8) by separating along the half-etched line. Discard the smaller piece, and solder the larger one in place as per the sketch. The tender assembly can now be washed to remove flux residues before proceeding further (sketches 2 & 3).
7. Fold the front platform inner support (10) to shape and solder to the underside of the front platform (11), making sure the top edges of the former are located in the inner half-etched lines of the latter, and that the inner support is the correct way up. File a notch in both the inner front platform etch and the base of the tender front casting to clear the tender chassis/frame fixing screw. Fettle the tender front casting and check for fit against the front bulkhead - it should slide into position between the front edges of the tender sides. With the tender front casting in position (but not fixed) slide the front platform up to it and check the fit - the brake and water scoop covers should fit snugly on top of the platform. Fettle as required and when satisfied fix in position with adhesive, since you may find it difficult to make a hidden or neat

solder joint.

- The remaining detail may be added in any order as per the sketches. The water scoop and brake operating handles are made from handrail knobs and 0.45mm wire as per the sketch (sketch 6 and below).

This completes the assembly of the tender body, and detailing of the underframe can now be completed as described in the TF2 or TF3 instructions.

Remove this piece of brass before doing anything further to the tender side. It is used only to give us something to grip whilst forming the curve.

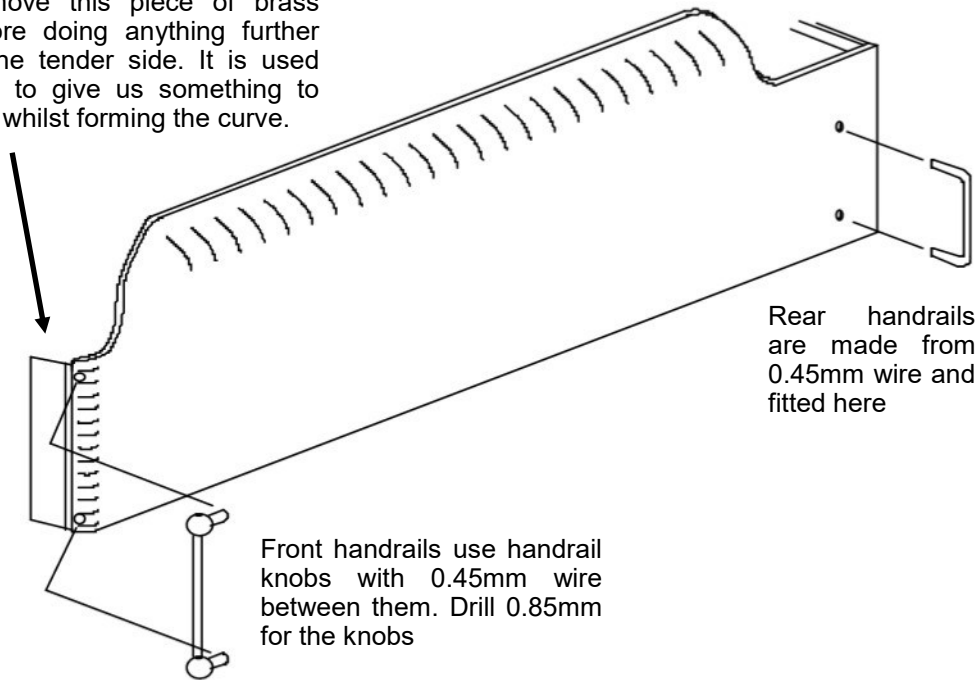

Please note that the lamp irons, works plate and capacity plate are not provided. We make the lamp irons from 'Bambi' staples cut in half. The works and capacity plates are available from other manufacturers.

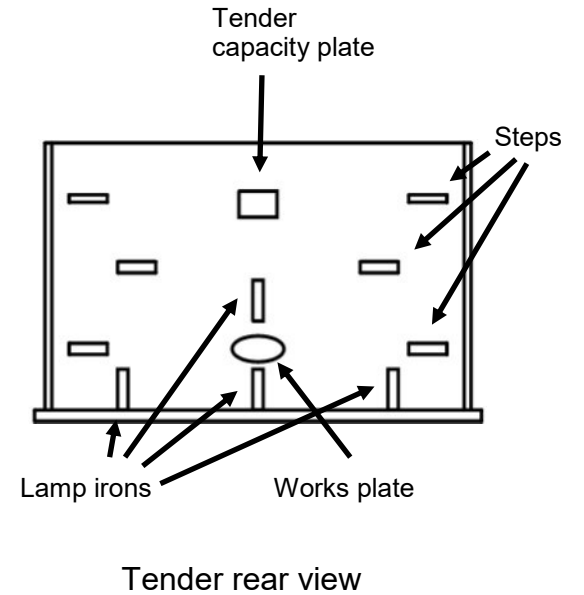

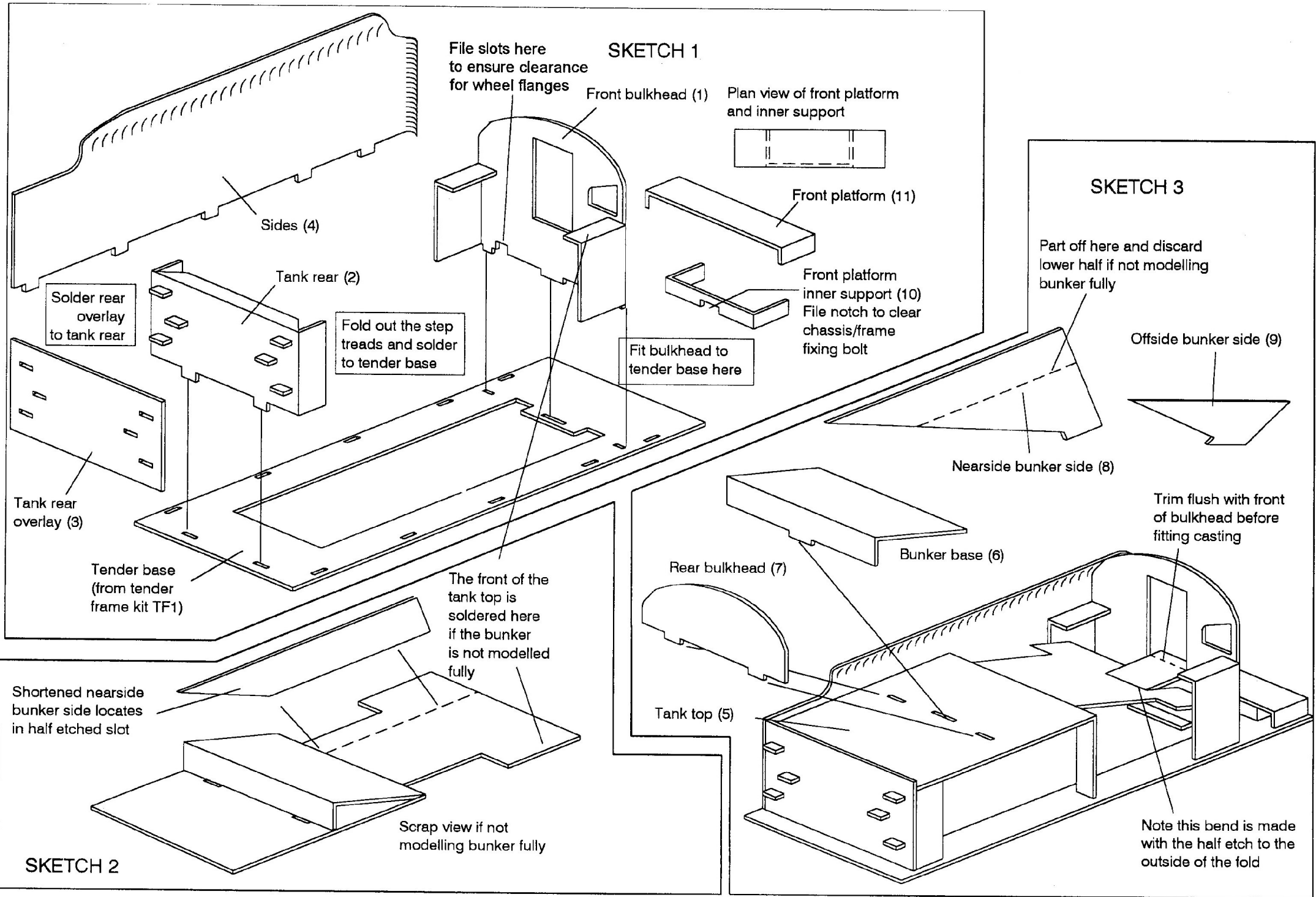

**SKETCH 1**

**SKETCH 3**

**SKETCH 2**

File slots here to ensure clearance for wheel flanges

Plan view of front platform and inner support

Front platform (11)

Front platform inner support (10)  
File notch to clear chassis/frame fixing bolt

Fit bulkhead to tender base here

Part off here and discard lower half if not modelling bunker fully

Offside bunker side (9)

Nearside bunker side (8)

Trim flush with front of bulkhead before fitting casting

Bunker base (6)

Rear bulkhead (7)

Tank top (5)

Note this bend is made with the half etch to the outside of the fold

Sides (4)

Tank rear (2)

Solder rear overlay to tank rear

Fold out the step treads and solder to tender base

Tank rear overlay (3)

Tender base (from tender frame kit TF1)

The front of the tank top is soldered here if the bunker is not modelled fully

Shortened nearside bunker side locates in half etched slot

Scrap view if not modelling bunker fully

Fold offside bunker side as shown and solder in position. The cast fire iron tunnel fits on top of this flush with the cut-out in the bulkhead

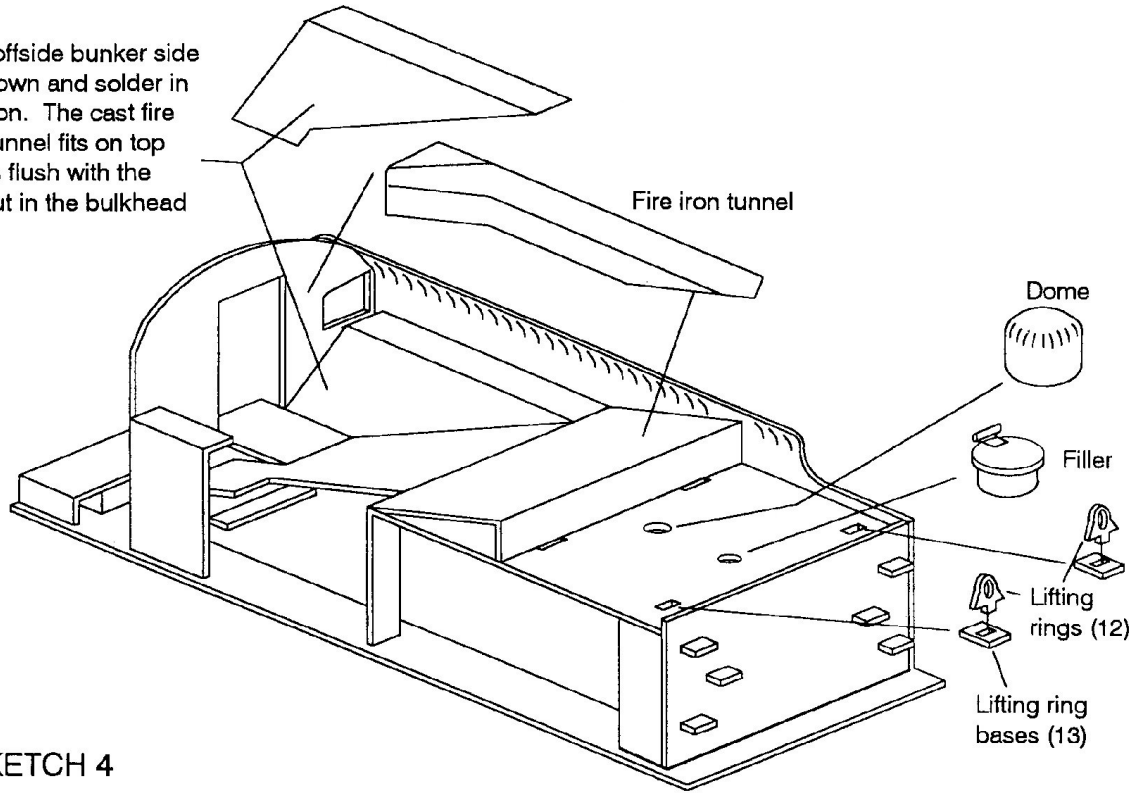

SKETCH 4

SKETCH 6

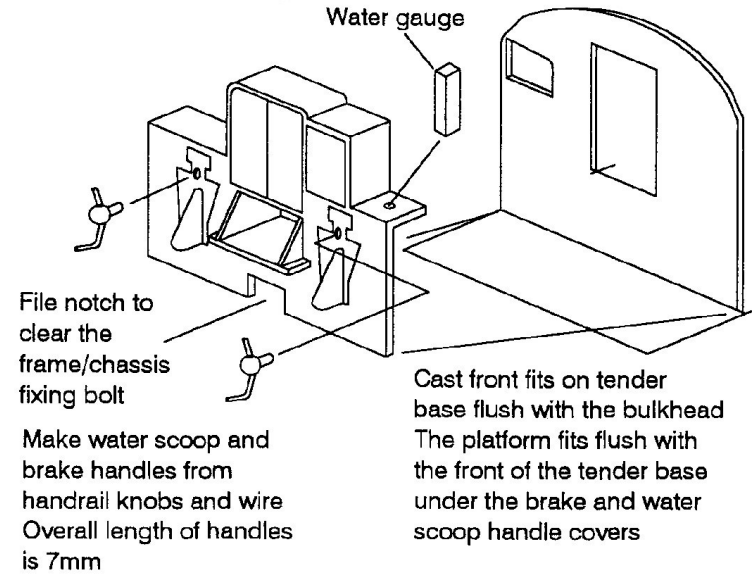

Cast front fits on tender base flush with the bulkhead  
The platform fits flush with the front of the tender base under the brake and water scoop handle covers

Make water scoop and brake handles from handrail knobs and wire  
Overall length of handles is 7mm

File notch to clear the frame/chassis fixing bolt

When the tank top and the bunker sides are in position trim this projection back flush with the bulkhead to allow the tender front to fit flush

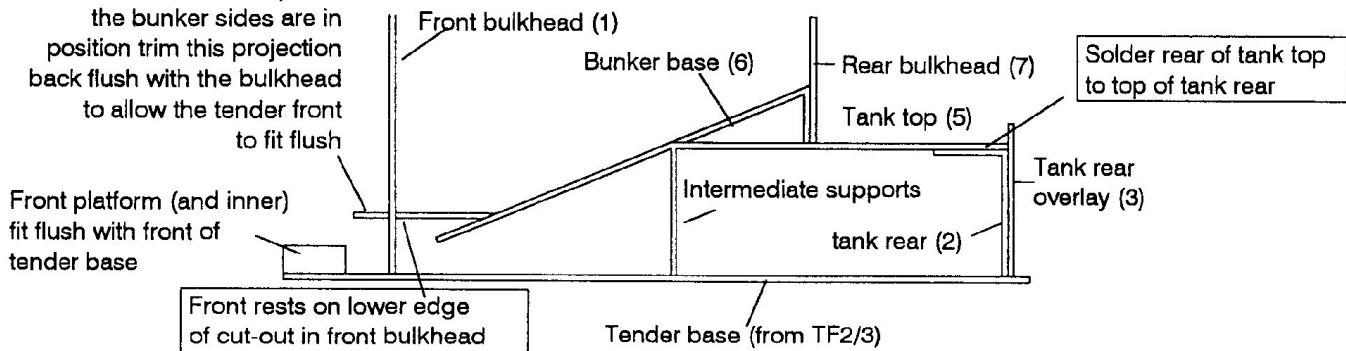

Disposition of tank top (5) if modelling the coal bunker fully

SKETCH 5

SKETCH 7

These tenders had vents to the Ivatt pattern, similar to those on contemporary Class 2 and Class 4 2-6-0 locos. They were mounted flat against the back surface of the rear coal bulkhead.

