

B19 BR Mk1 RESTAURANT BUFFET (RB)

D24

**128 built 1960-1962; withdrawn 1980-2012; 39 preserved or in railtour use
64'6"**

These etched sides can be built into a complete coach using products from our range as supplied in our full kits. Please refer to the panel opposite. They can also be used as a basis for a scratchbuilt coach, or to overlay a suitable ready to run model.

These coaches were built by two companies, the Birmingham Carriage and Wagon Co. Ltd (BRCW) and Pressed Steel Fisher Ltd (PSF). They were allocated to all the British Railways regions.

Sample formations

1963 Euston-Stranraer-Perth-Aberdeen	BSK/SK/SO/SO/RB/FO/BFK
1965 Thames-Clyde Express	BSK/SK/SK/SO/SO/RB/FO/FK/CK/BSK
1963 Leeds-Glasgow	BG/BSK/SK/SK/RB/SO/CK/CK/SK/SK/BSK
SR sets 277/8 Waterloo-Weymouth	BSK/SO/SO/CK/RB/CK/SO/SO/SK*/BSK
SR set 880 Bournemouth-Newcastle	BSK/CK/SO/SO/RB/SO/SO*/CK/BSK
	*Either Bulleid or BR Mk1 vehicles

Running numbers and original regional allocations

W1644-1657	built 1960/61	PSF	S1716-1724	built 1960-61	BRCW
Sc1658-1662	built 1960	PSF	W1725-1732	built 1960	BRCW
E1663-1699	built 1960-62	PSF	Sc1733-1738	built 1961	BRCW
M1701-1713	built 1960-62	BRCW	W1739-1754	built 1961	BRCW
E1714/15	built 1960-61	BRCW	S1755-1772	built 1961-62	PSF

The BRCW builds except 1739-1754 had BR B2 bogies (Comet BB1); all other carriages had the Commonwealth type (Comet BB2). 1714-24 were converted in 1967 to 4-REP EMU cars.

Livery

On introduction these coaches were painted maroon lined gold/black/gold at the waist and black/gold above the windows. Ends were painted black. From 1965 onwards, where spray painting of the coaches was introduced, the ends were painted body colour to avoid the need for masking.

Also from 1965 the new "corporate image" livery of blue/grey was introduced. The grey was not carried to the end of the coach and there was a white line between it and the blue. Lettering and insignia were white.

Further information

British Railways Mk1 Coaches	Keith Parkin	Pendragon
BR Mk1 & Mk2 Coaching Stock	Hugh Longworth	OPC

Modelling notes

These vehicles had under floor water tanks, hence they did not have water filler pipes to the roof. If building a kit, the step detail should be removed from both end castings.

On the kitchen side, the extreme left hand window and the short windows in the kitchen and pantry had white glass, as did the top section of the staff compartment window, the lower section being frosted.

The V hangers on the standard underframe etch (Comet Models code UB1) should be discarded and replaced with parts "F" on the detail etch included with the coach sides pack.

COMET MODELS components required to complete this carriage are:

Underframe	UB1	Bogies	BB1 or BB2
Underframe castings	UCB1	Interior	INT4
Ends	EB1	End castings	ECB1
Roof	C10	Roof castings	RC3,RC4,RC7

Scrap views showing additional detailing of sides and ends

(not all details may apply to this diagram)

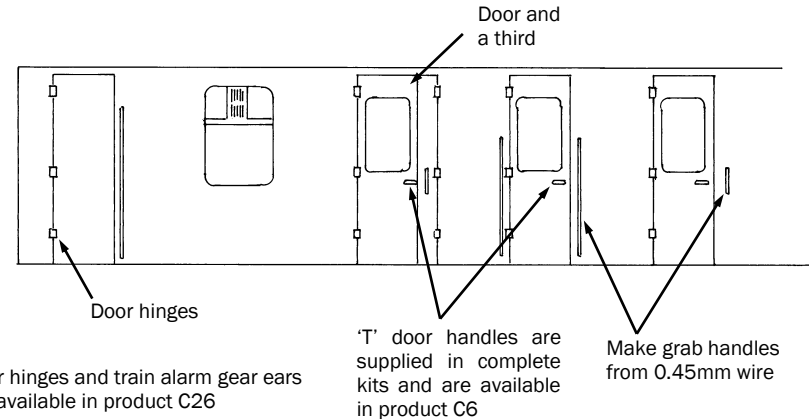

The ends are identical except that the train alarm gear is fitted only at the end shown on the roof plan

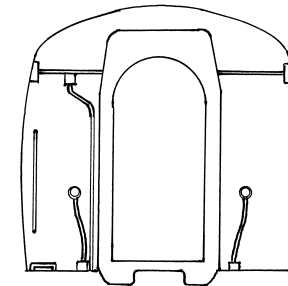

D24

Train alarm gear this end

Large fan cowls

Note that these coaches were fitted with a pumped water supply. There were no roof mounted tanks or filler pipes, and no steps on the coach ends.

C
L

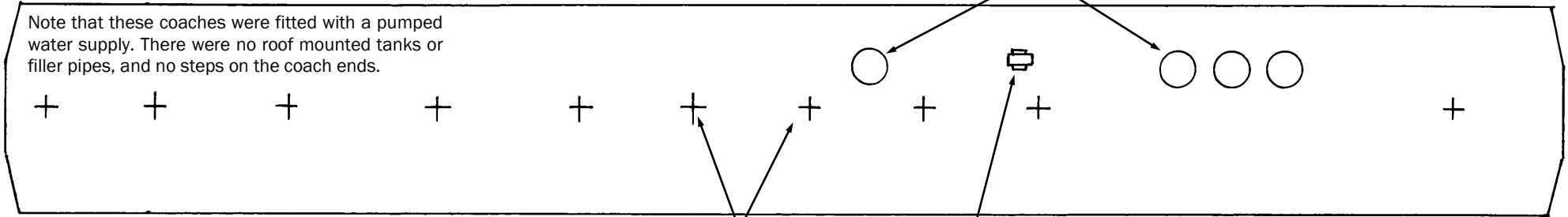

**ROOF AND INTERIOR PLANS
VIEWED FROM ABOVE**

Ridge dome
vents

Small monsoon vent

Cut floor to
clear end

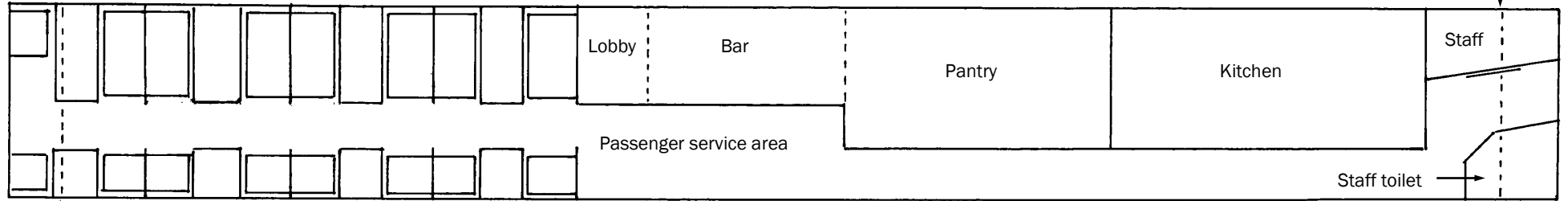

Cut floor to
clear end

Switch box
w/m casting

Control box C

Propane storage B

Control box A

Common edge

UNDERFRAME VIEWED FROM BELOW

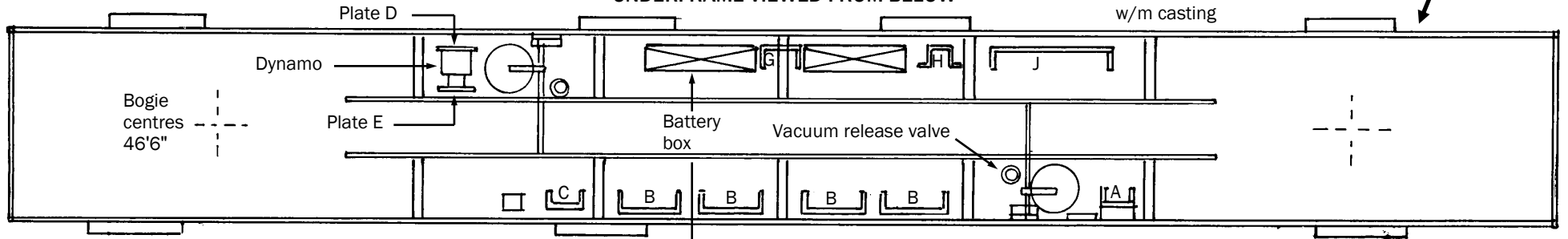

Solebar
stepboard

Dynamo
with end
plates D&E

Vacuum
cylinder

Angled V
hanger part F

Vacuum
release valve

Control
box G

Battery
box

Control
box H

Refrigeration
equipment J

D24 UNDERFRAME EQUIPMENT D24

Reinforce folds with a fillet of solder. Fit the additional equipment to the back of the solebar with reference to the underframe plan. Fit the cast cross trusses **after** fitting the additional equipment

Electrical control box A

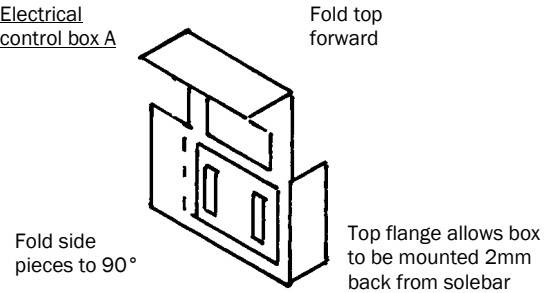

Propane storage box B (4 off)

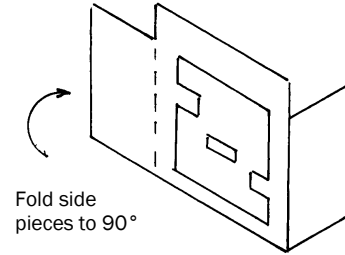

Control box C

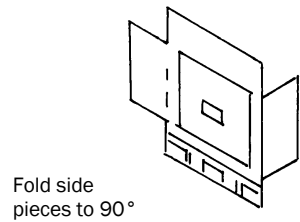

Modifications to the standard dynamo for the 10kW version

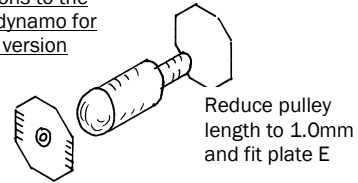

File a flat on the domed end and fit plate D

Electrical control box part G

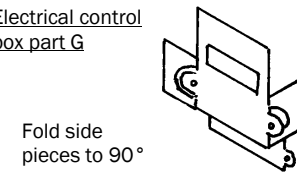

Double fold lower section to set it back

Propane control unit H

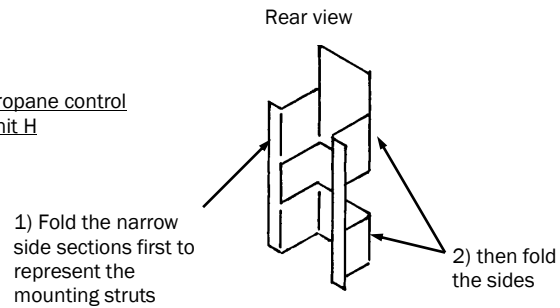

Refrigeration equipment J

