

## UW1 UNDERFRAME for GWR 70' CARRIAGES

### Assembly instructions

1. Remove the parts from the fret, including those which are etched within the floor area, but **do not** remove the angle trussing.
2. This underframe provides for 70' prototypes. Drill out the bogie centres to give clearance for M2.5 screws.
3. Bend up the edge of the floor and reinforce with a fillet of solder.
4. Offer up the underframe to the coach end/sides/roof assembly, and fettle the ends of the floor if necessary to achieve a drop-in fit. If you are using COMET MODELS ends refer to the separate instructions supplied with them.
5. Fold the bottom lip of the solebars and reinforce with a fillet of solder applied from the rear. Fix the solebars to the floor through the etched slots and locating tabs, taking care to ensure that they are vertical. The buffer beams from the COMET MODELS end pack are next fitted to the ends of the solebars.
6. Detach the angle trusses from the floor **at the outer ends only**. Fold the angle trusses down from the floor, and fix to the inside face of the solebars. Note that on underframes adaptable to more than one coach length it is possible for strict accuracy to bend the diagonals slightly at the queen posts to alter the angle and reach before finally fixing the outer ends to the solebar in the desired position.

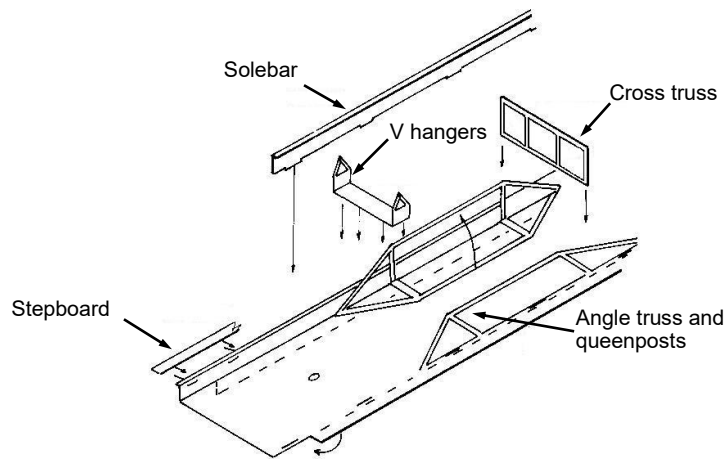

7. If you are constructing a coach with a turnbuckle underframe this can be depicted as follows.

Bend a piece of 0.7mm wire to a "U" shape to represent the queenposts, so that the distance between the uprights is 47mm. Solder this centrally to the coach floor, against the back of the solebar.

File a notch in the inside face of the queenposts 6.5mm below the bottom of the solebar to locate the wire angle truss.

Bend a second piece of 0.7mm wire so that the bend coincides with the outside of the queenposts. Allow sufficient extra length at both ends for fixing behind the solebar.

Solder the wire truss in place into the notches on the queenposts, adjusting the angle with pliers so that the truss disappears behind the solebar 45mm outside the queenpost, then solder the outer ends in place.

Trim back the ends of the queenposts to give a projection of 1mm.

Repeat for the other side.

Some coaches had four trusses equally spaced across the floor. The intermediate ones can be depicted as described above, though you could choose to represent the queenposts more simply by marking and drilling the centres and inserting short pieces of 0.7mm wire then soldering them in place.

The turnbuckles themselves can be represented by short lengths of fine wire sheath, cut to length, split lengthwise and glued in place

8. The remaining underframe detailing can be carried out in any sequence. Drill the 'V' hanger cross rod holes to 0.75mm then fold them up and fix in position. Stepboards may be fashioned from the outer frame of the etch. The position of the stepboards is given on the underframe plan contained in the coach sides pack. We suggest they are fixed by drilling through the solebar face and inserting 0.45mm wire supports to which the stepboard is then soldered.

