



**LM17 Motion Set for
LM42 LMS Fairburn 2-6-4T
& BR Class 4 2-6-4T**

COMET MODELS components complementing this motion set are:			
For Fairburn loco	Frames		LF17
Crosshead	LS8	Bogie	LS5
Pony truck	LS2	Cylinders	LC1
For BR loco	Frames		LF42
Crosshead	LS8	Bogie	LS4
Pony truck	LS2	Cylinders	LC5

This motion set etch is designed to fit our loco frame packs LF17 and LF42. All folds should be made with the half-etch to the inside, and reinforced with solder. All parts are numbered on the etch and are identified in the instructions by the number in brackets. Where components are handed they are marked on the etch 'L' for left (nearside) and 'R' for right (offside). We recommend that all holes are drilled before you remove them from the fret, with the exception of the coupling and connecting rods which are best drilled after assembly. Drill 0.85mm for rivetted joints.

NOTE: Crossheads and pins are NOT supplied in this pack, but are available separately - COMET MODELS pack LS8.

We strongly recommend that the cylinder and motion bracket assemblies are arranged to bolt on to the frames so that everything can be stripped down and re-assembled as required, otherwise you are sure to finish up with an axle nut or whatever hidden behind the motion. A little forethought when positioning the frame spacers for chassis assembly will facilitate this.

Parts List

- | | |
|----------------------------|--|
| 1. Coupling rods | 10. Combination lever |
| 2. Coupling rod overlays | 11. Valve rod |
| 3. Connecting rods | 12. Return crank |
| 4. Connecting rod overlays | 13. Eccentric rod |
| 5. Slidebars | 14. Expansion link |
| 6. Motion bracket | 15. Expansion link pivot bracket (outer) |
| 7. Motion bracket overlays | 16. Expansion link pivot bracket (inner) |
| 8. Drop link | 17. Lifting arm |
| 9. Union link | 18. Eccentric rod bearing overlay |

Assembly sequence

1. Fix the outer coupling rod overlays [2] to the plain inner rods [1] - note that the rods are handed. If you wish to articulate the rods, the inner rod should be split at the half-etched marks before assembly
2. Fix the outer connecting rod overlays [4] to the plain inner rod [3] - note the rods are handed.
3. Assemble the connecting rods and drop links [8] to the crossheads (COMET MODELS pack LS8). Insert the pin from the rear, solder it to the outer face of the drop link, then cut and file it flush (see sketch). Note that the pin locates in the hole in the half-etched section of the drop link.
4. Assemble the slide bars [5] to the cylinder rear covers as per the sketch, and fettle as

necessary to achieve an easy sliding fit of the crossheads.

5. Using the rivets supplied, assemble the drop link [8] to the union link [9], the union link to the combination lever [10], and the combination lever to the valve rod [11]. Note that the union link is outside the drop link and the combination lever is outside both the union link and the valve rod. Note that the assemblies are handed.
 6. Assemble the return crank [12] to the eccentric rod [13], noting that the eccentric rod is outside the return crank. If you wish to add the bearing overlay (18) you will need to make this a soldered joint using a bright plated steel pin (not supplied) inserted from the rear, soldered on the outer face of the eccentric rod, then cut and filed flush. This presents a flush surface onto which to glue the overlay. The expansion link [14] is supplied as a fold up unit, but if you prefer to simplify the assembly separate the outer link at A-A. If using the expansion link as supplied, fit the eccentric rod between the inner and outer links and fix with 0.7mm wire soldered to both links, using paper washers to ensure freedom of movement. Alternatively, if using only the outer link, rivet it to the outside of the eccentric rod.
- NOTE:** Refer to the sketch for the nearside valve gear - but remember to transpose from left to right when assembling the offside valve gear.
7. Fold up the rear half of the motion bracket [6] as per sketch and fix the front motion bracket overlays [7] in place. If using our frames LF17 or LF42 and aiming to fit the chassis to a Bachmann body, see the diagram overleaf to see the modifications required to the motion bracket. It may be necessary to increase clearance for oversized wheel flanges by filing the lower edge of the motion bracket. The inner and outer expansion link pivot brackets [15 & 16] can now be soldered in the slots in the rear face of the motion bracket. You will probably find it easier to solder both inner and outer brackets together on the same side using a length of 0.7mm wire through the pivot holes to keep them in position.
 8. Feed the end of the valve rod through the slot in the motion bracket and then through the centre of the expansion link, align this assembly with pivot holes and feed 0.7mm wire through, soldering in place using paper washers. Feed the 0.7mm wire through the rear fixing hole in the valve rod and the inner and outer lifting arms [17] and solder together, ensuring that both are aligned correctly - the holes in the front ends of the lifting arms should line up with the slot in the valve rod. The 'L'-shaped lifting arm should be fitted to the inner nearside, with the extension upwards. Now feed 0.7mm wire through, solder and file flush all projections. Repeat for the other side.
 9. Feed the crossheads into the slidebars and assemble the cylinders and motion bracket to the frames. The slidebars can now be trimmed flush with the rear face of the motion bracket. You may also need to trim the end of the valve rod (which represents the valve spindle) so that it butts up to the valve chest. Make sure that the cylinder and motion assemblies are bolted securely. Place the connecting rod over the driven crankpin and fix the return crank outside this remembering to allow a few degrees of forward lead on the return crank.

Motion bracket / valve rod assembly

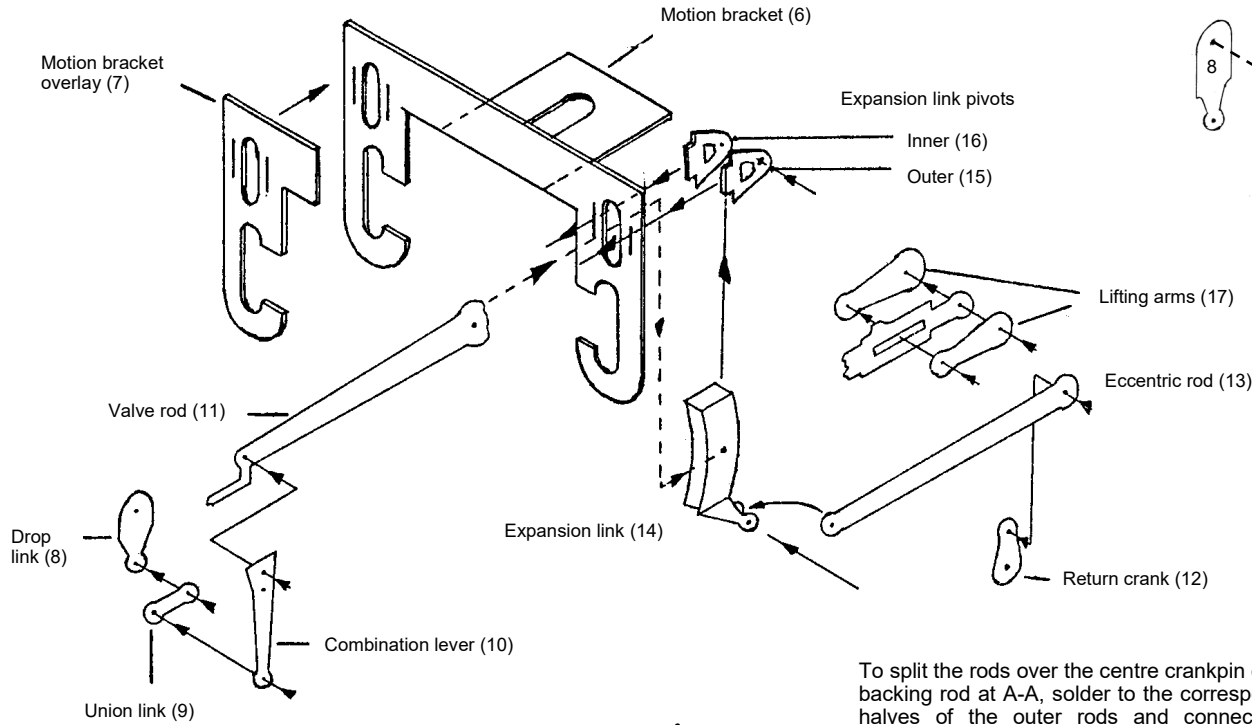

Crosshead assembly (viewed from rear)

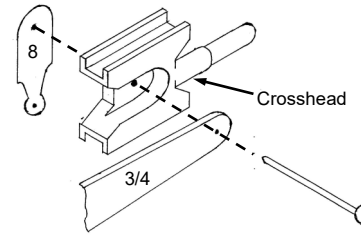

Slidebar assembly

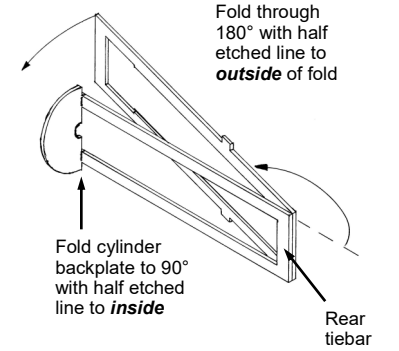

Expansion link

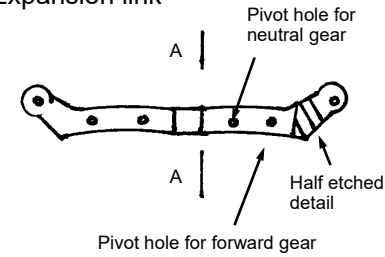

Valve rod / expansion link assembly

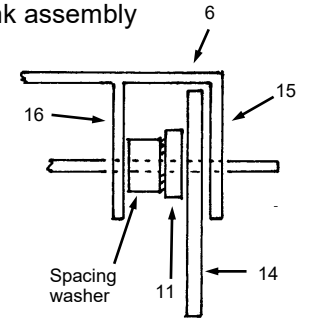

To split the rods over the centre crankpin cut the backing rod at A-A, solder to the corresponding halves of the outer rods and connect both halves at the centre crankpin.

Coupling rods assembly

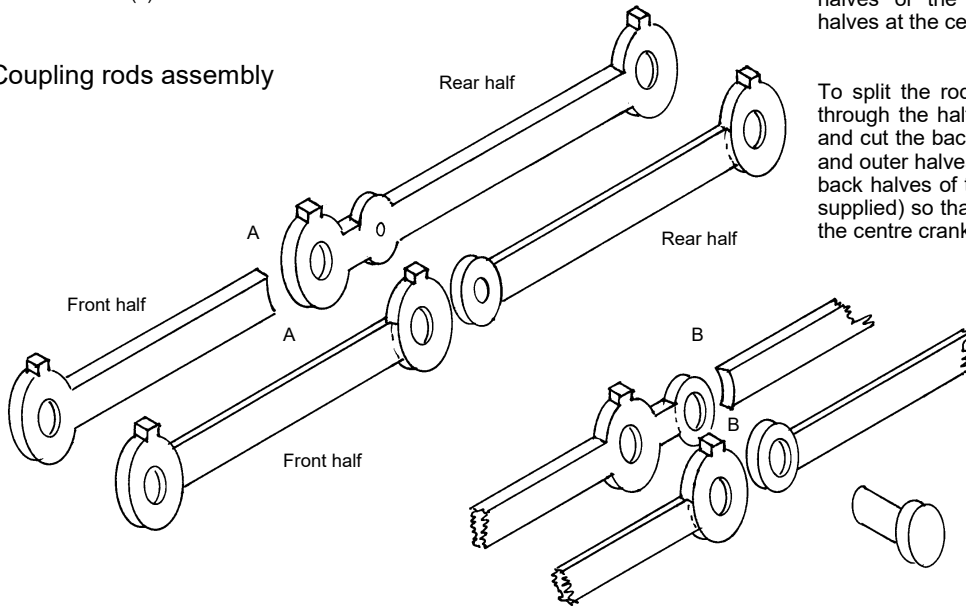

To split the rods on the knuckle joint first drill through the half etched centres on the knuckle and cut the backing rod at B-B. Solder the inner and outer halves together then join the front and back halves of the rods using a pin or rivet (not supplied) so that the rods are articulated behind the centre crankpin.

Motion bracket modifications when using Bachmann bodies

