

**LCP37 Chassis pack
for LNER
Gresley J39 0-6-0**

Components recommended to construct a complete chassis
6 Markits 5'2" wheels (WH205), 3 axles
6 crankpins and washers (RM2)
Gearbox GB5/15 fitted with a Drive Extender
Mashima MHK1020 motor

This etch contains sideframes, 00 spacers, brake shoes and brake pull rods to produce a basic chassis of the correct scale dimensions and appearance which can be used as a substitute for a kit or RTR chassis. We recommend the Mashima MHK1020 motor with our gearbox GB5/15 and a drive extender for this model, and can supply the latter two together with Markits driving wheels if required. EM spacers are available separately, code LS10, as are P4 spacers, code LS60.

As supplied the frames are suitable for the Bachmann model.

Please note that all bends should be made with the half-etch to the inside and reinforced with a fillet of solder.

Etched parts list

- | | |
|---------------------|--------------------------|
| 1. Loco frames | 4. Brake pull rods |
| 2. 00 frame spacers | 5. Coupling rods |
| 3. Brake shoes | 6. Coupling rod overlays |

Assembly Instructions

1. Although designed primarily as a rigid chassis, compensation systems such as Perseverance, MJT or Sharman Wheels can easily be used if the hornways are cut out at the half-etched lines before starting assembly.
2. Carefully open out the axle bearing holes in the frames until the bearings are a close fit, ensuring the bearing flanges fit snugly against the frames. This is best done using a five sided broach. If you are using our chassis jigs (see below), DO NOT solder the bearings in place at this stage. Open out the holes for the brake cross-shafts to 0.75mm.
3. Select the appropriate frame spacers - their size and position will depend upon the siting of the body fixings and your preferred motor/gearbox and pick-up arrangements. Our own preferences are, where possible, for a tongue and slot fixing at the front buffer beam and a single bolt fixing under the cab, together with wiper pick-ups mounted below the chassis. A suitable layout of spacers is shown to suit this and our gearbox GB5/15 fitted with a Drive Extender and Mashima MH1020 motor.
4. The frame spacers fold to right angles on the half-etched line. Solder your chosen ones to one of the frames, then assemble by clamping the other sideframe to the first using the wheelsets to check alignment before soldering the second sideframe. This crucial stage of the assembly can be achieved more easily and with greater accuracy by using our frame assembly jigs (code LS16 for 00, LS17 for EM and LS61 for P4). Full instructions are provided with them.
5. With the frames assembled, solder lengths of 0.7mm wire through the brake hanger holes, then thread on and solder the brake shoes in place. Alignment of them is made easier if something of suitable thickness is used to space out the brake shoe from the frame, with a wheelset fitted to ensure correct spacing relative to the wheel treads.

6. Lengths of 0.7mm wire are next threaded through the bottom brake hanger holes on one side of the chassis, through both sets of pull rods (ensuring they are the correct way round) and then through the second set of brake hangers. Solder the wire to the brake hangers, then slide the pull rods outwards to line up with the inner edges of the frames and solder them to the wire. Finally, solder on fixing nuts for the pick-ups.
7. The coupling rods can be articulated if desired by cutting the full length backing rod as shown before soldering on the overlays. Whether you articulate the rods or not, this operation is simplified if the crankpin holes are first drilled (1.2mm for Markits crankpins), and the backing rod tinned along its length. Both the backing rod and the overlay can now be threaded onto the drill which will keep one end in alignment whilst the other is squared up and the rods soldered together (see sketch). If using Markits wheels you will need to use a paper washer between the coupling rod and the crankpin washer to prevent the rods being soldered to the crankpins. These locos had both plain and fluted rods - check a photo of the one you are modelling to see which you should use.

The chassis can now be washed to remove flux residues, but before painting we suggest that you fit the wheels and check the fit of the body. You may find some slight filing is required to obtain a perfect fit.

Our preference is for wiper pick-ups made from 26swg phosphor bronze wire as per the sketch. The wire is soldered to PCB strip which is bolted to a frame spacer. We recommend that, if possible, you arrange the pick-up to be "bolt on" since this allows for easy removal and adjustment of the wire wipers. Pack LS23 provides all the parts.

Suggested position of frame spacers

Spacer A	10mm x 10mm
Spacer B	10mm x 6mm
Spacer C	6mm x 6mm
Spacer D	6mm x 3mm

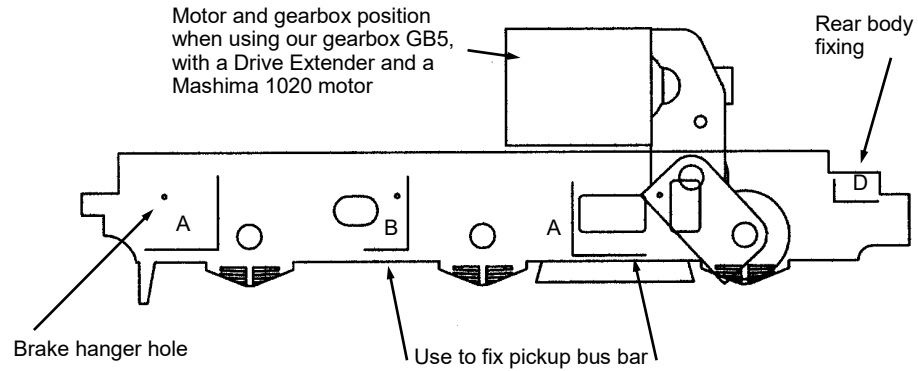

Use the shank of the drill you have drilled out the holes with to hold the rods in line whilst you solder them together

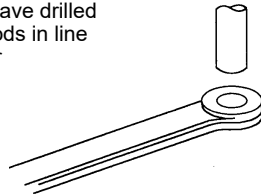

Arrange 26swg wire to produce optimum pressure on back of wheel

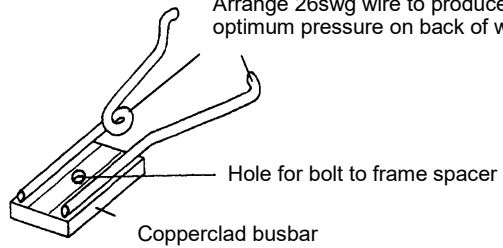

Solid rods

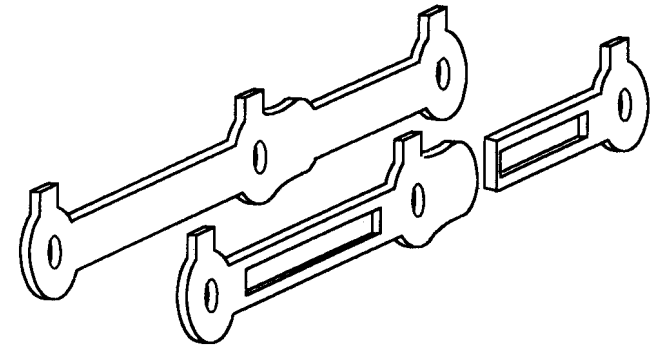

If you are using solid rods just solder overlays to backing rod

Jointed rods

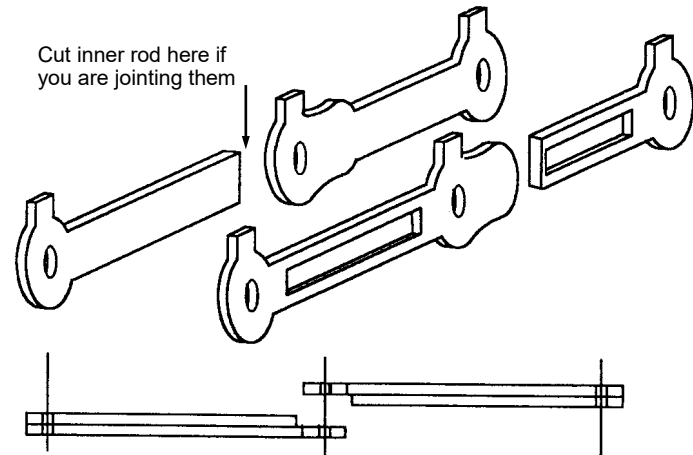

Arrange over the crankpins as above if you are articulating the rods