

## M21 LMS PERIOD II OPEN THIRD (TO)

D1807

299 built 1931-1932; withdrawn 1955\*-1966; none preserved

57'

\*- 6 withdrawn before 1948

These etched sides can be built into a complete coach using products from our range as supplied in our full kits. Please refer to the panel opposite. Should you prefer they can also be used for scratchbuilding.

This open third was the most numerous Period II design. The etch represents the 1931 build, so if you wish to model the 1932 version it should be modified to show hooded vents over all the windows except the second and fifth where Stones vents should be fitted.

### Sample formations

Inverness-Kyle 1938

CK/CK/RU/TO/TO/BG

Western Division extras/excursions

BCK/TO/TO/TO/TO/BTO

BCK/TO/TO/TO/TO/TO/TO/BTO

### Running numbers

8581-8720 built 1931 at Derby

8781-8830 built 1932 at Wolverton

8721-8780 built 1931 at Wolverton

8831-8879 built 1932 at Derby

1931 builds had panel lining between windows. 1932 builds had suspended gangways.

1951 Push-pull conversions: 8723/48/8865 became 3484/5/6

### Livery

The LMS coach body colour was maroon. Ends were also maroon with the detail picked out in black, but from the end of 1936 they were painted all over black. Fully panelled livery was applied with lining in black and gold leaf, later yellow. On flush sided coaches the lining was laid out as though the coach was panelled (so called 'pseudo-panelling'); sometimes the verticals were at the edges of the window frames, otherwise they were on the centre of the panel between them. Simple lining was adopted at the beginning of 1934. In 1946 the yellow was replaced with a much lighter shade referred to as 'straw'. From 1949 coaches received BR crimson and cream. From 1956/7 BR maroon with simple lining was adopted.

Number and lettering styles, insignia and class designation placement did not always follow the changes of livery. For further information on a particular vehicle at a specific date please consult references and photographs.

Early coaches received lead grey roofs with black between the cantrail and rainstrip. All steel and later flush sided coaches had a metallic aluminium paint finish. However, in service the roof quickly took on an overall muddy grey colour.

Underframes and bogies were finished in black.

### Further information

LMS Standard Coaching Stock Vol. II  
Historic Carriage Drawings

Jenkinson & Essery O.P.C.  
Jenkinson & Campling Ian Allan

Passenger Train Formations  
1923-1983 LMS LM Region

Clive S Carter Ian Allan  
H Longworth O.P.C.

British Railways Pre-Nationalisation Coaching Stock Vol. 2

COMET MODELS components required to complete this carriage are:

Underframe	UM2	Bogies	BM2
Underframe castings	UCM1	Roof castings	RC1
Ends	EM3	End castings	ECM1/2
Roof	C10	Interior	INT4

### Scrap views showing additional detailing of sides and ends

(not all details may apply to this diagram)

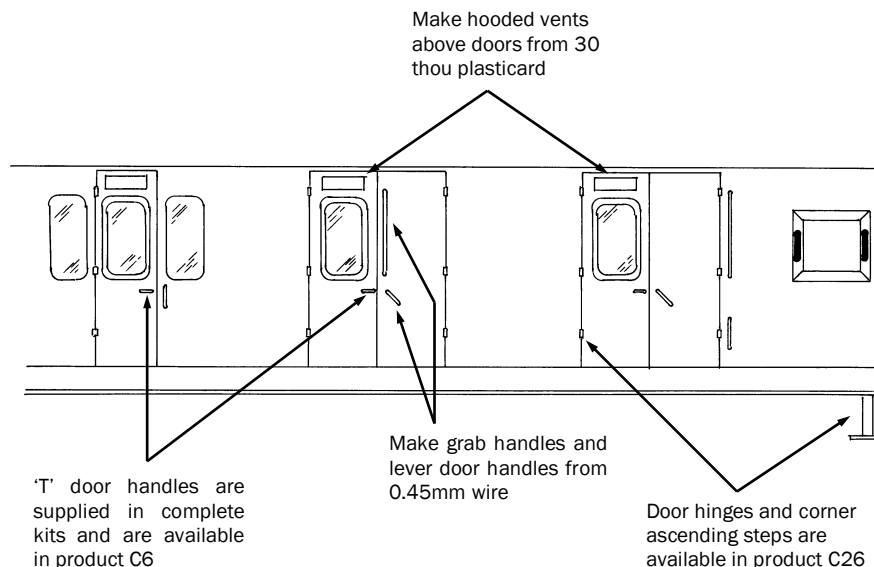

The ends are identical except that the train alarm gear is only fitted at the end shown on the roof plan overleaf

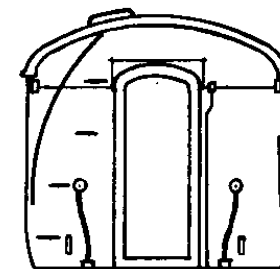

Train alarm gear this end

D1807

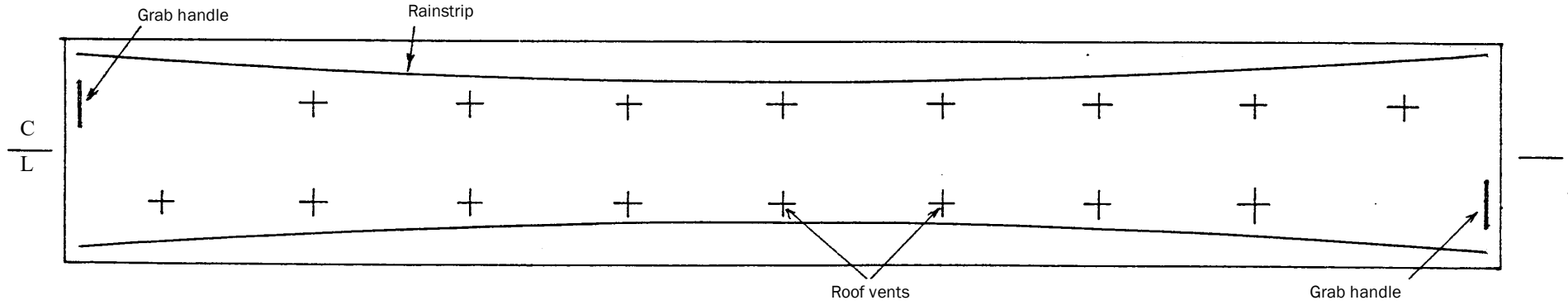

**ROOF AND INTERIOR PLANS  
VIEWED FROM ABOVE**

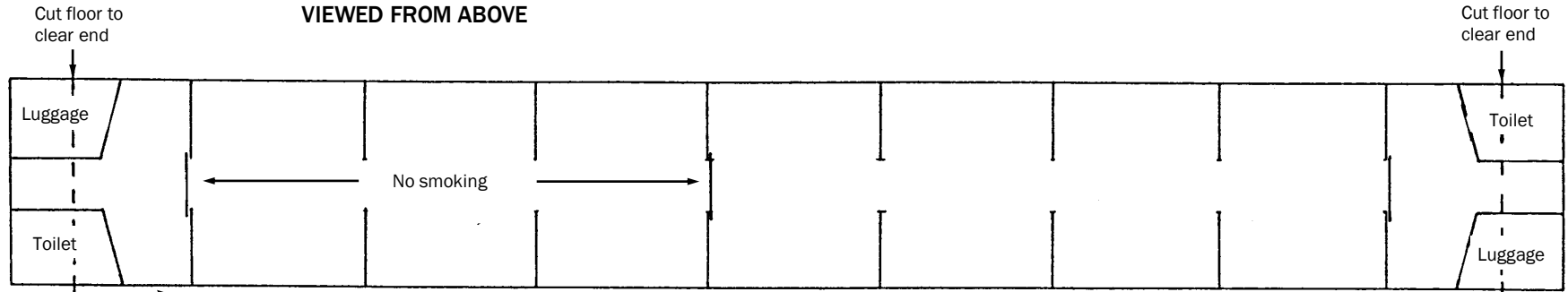

**UNDERFRAME VIEWED FROM BELOW**

