

## LS4 Locomotive Bogie 6'3" wheelbase

### IMPORTANT - Please read the instructions *before* starting the assembly

This product is part of our complementary range of loco chassis components but it may also be used to enhance RTR products, replace those found in kits, or for scratchbuilding.

### ASSEMBLY INSTRUCTIONS

1. Refer to sketch A. Remove the main stretcher from the fret. For 00 gauge fold up the sides and centre cross members to 90° and reinforce with solder.
2. For EM or P4 select the appropriate alternative centre stretcher and fold up the sides as shown in sketch B. Separate the sideframes from the 00 stretcher at the half-etch lines. Pass two lengths of 0.45mm wire through the holes in the sides of the stretcher, thread on the two sideframes and solder in place. Clip off the excess wire and clean up the outer faces of the sideframes.
3. Check that a 2.0mm diameter axle will drop into the hornways and fettle if necessary to achieve an easy fit. Solder the sideframe overlays to the outer faces of the sideframes. You can use an axle or wheelset to ensure accurate alignment.
4. If you wish to mount the bogie using the swing link provided, solder a nut to the underside of the pivot hole in the centre of the stretcher and bolt the swing link in place, allowing a small amount of vertical play. Solder the bolt to the nut, using a paper washer to ensure the link remains free to swing.
5. Solder the two bottom detail pieces centrally to the inside faces of the stretcher and solder two lengths of 0.7mm wire through the holes at the ends of the sideframes. Fit the wheelsets and retain them in the hornways by passing lengths of wire through the indicated holes in the centre cross members. Bend the guard irons to align with the wheel treads.
6. Solder a washer over the slot in the swing link and adjust the position as required until the axle is located on the correct centre line.

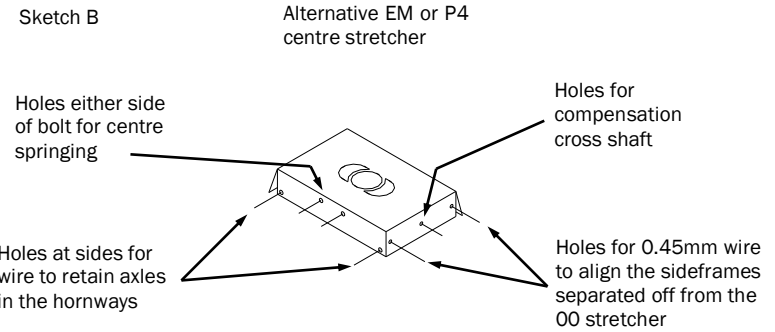
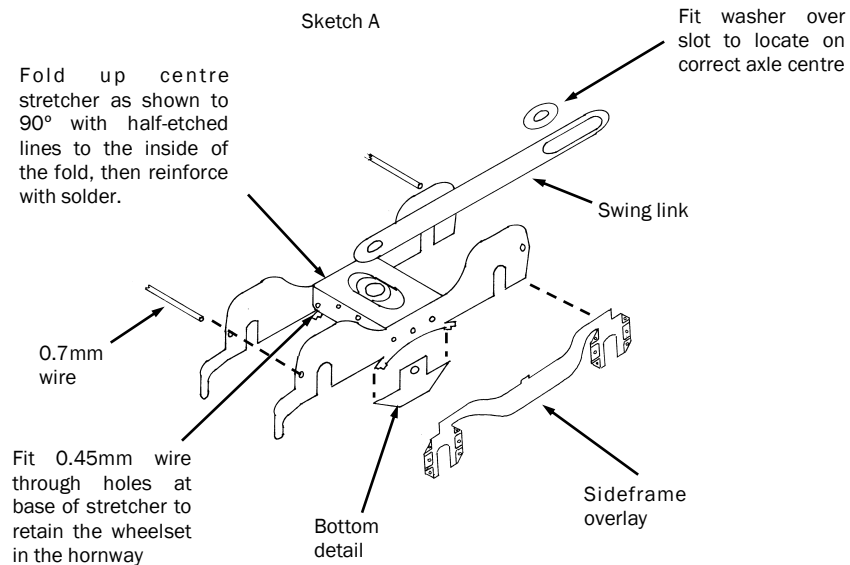

Performance of the chassis will be improved if the bogie is weighted or sprung to aid track holding, and especially if some form of centre springing is employed so that the bogie, as on the prototype, helps the chassis to steer into curves by exerting a sideways force on the frames as shown in sketch C.

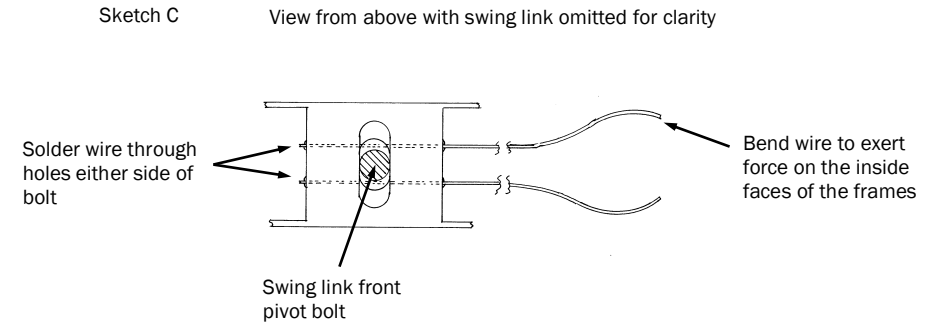

An alternative means of mounting the bogie to the chassis is shown in sketch D. The centre pivot hole in the stretcher is removed at the half-etch lines and the inner edges smoothed to provide a lateral slot. The bogie is fixed in place by the shouldered bolt into a chassis spacer with a nut soldered accurately on the bogie centreline. Wire can be fed through the holes in the centre cross members to provide a strong centre springing action to guide the chassis into a curve. This method of mounting also allows the use of a soft compression spring for downforce to aid good track holding. Holes are provided on the lateral centre lines of the stretchers and sideframes, with half-etched centres on the sideframe overlays as an aid to compensation of the bogie wheelbase if desired.

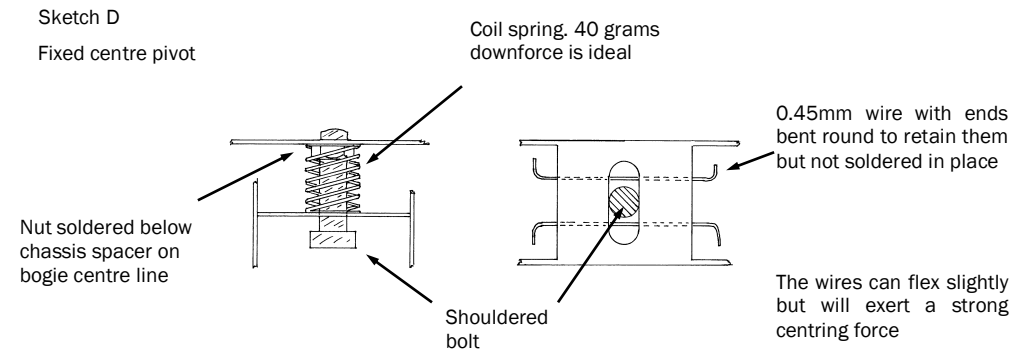

Comet Models is part of Wizard Models Limited, PO Box 70, Barton upon Humber DN18 5XY  
Tel 01652 635885, web [www.wizardmodels.ltd](http://www.wizardmodels.ltd), e-mail [info@wizardmodels.ltd](mailto:info@wizardmodels.ltd)