



LM30 Motion Set for Gresley LNER A1/A3/A4 4-6-2s

COMET MODELS components complementing this motion set are:

Frames	LF30	Bogie	LS11
Cylinders	LC4	Crossheads	LS9
Axleboxes	LS14		

Beware the sharp point on part 20 when unpacking

This motion set etch is designed to fit our loco frame pack LF30. All folds should be made with the half-etch to the inside, and reinforced with solder. All parts are numbered on the etch and are identified in the instructions by the number in brackets. Where components are handed they are marked on the etch 'L' for left (nearside) and 'R' for right (offside). We recommend that all holes are drilled before you remove parts from the fret, with the exception of the coupling and connecting rods which are best drilled after assembly. Drill 0.85mm for rivetted joints.

NOTE: Crossheads and pins are NOT supplied in this pack, but are available separately - COMET MODELS pack LS9.

We strongly recommend that the cylinder and motion bracket assemblies are arranged to bolt on to the frames so that everything can be stripped down and re-assembled as required, otherwise you are sure to finish up with an axle nut or whatever hidden behind the motion. A little forethought when positioning the frame spacers for chassis assembly will facilitate this.

If you wish to model the expansion link assembly as per the prototype please refer to section 10. The main instructions provide for a simplified version which should be acceptable to most people.

Parts list

- | | |
|----------------------------|--|
| 1. Coupling rods | 12. Expansion link overlays |
| 2. Coupling rod overlays | 13. Lifting arm |
| 3. Connecting rods | 14. Motion bracket |
| 4. Connecting rod overlays | 15. Inner expansion link supports |
| 5. Slide bars | 16. Trunnion covers |
| 6. Union link | 17. Valve rod fork |
| 7. Combination lever | 18. Slide bar support |
| 8. Valve rod | 19. A3 reversing rod |
| 9. Return crank | 20. A4 reversing rod - beware the sharp point! |
| 10. Eccentric rod | 21. Reversing linkage |
| 11. Expansion link | Pack of 10 rivets |

Assembly sequence

1. Fix the outer coupling rod overlays (2) to the plain inner rods (1) - note the rods are handed. If you wish to articulate the rods, the inner rod should be split at the half-etched marks before assembly.
2. Fix the outer connecting rod overlays (4) to the plain inner rods (3). Note the rods are handed, the half-etch on the inner rod being to the inside (see sketch).
3. Using the rivets supplied, assemble the union link (6) to the combination lever (7) and the combination lever to the valve rod (8). Note the combination lever is outside both the union link and the valve rod. Note the assemblies are handed.
4. Fold up the slide bars (5) as per the sketch and check that the crossheads are a good sliding fit, fettling as required. Assemble the connecting rods to the crosshead (pack LS9) using the plain wire in the crosshead pack as the pivot, noting that the connecting rod fits into the fork of the crosshead. Assemble the union link (6) to the outside of the crosshead drop link - insert the pin from the front, solder it to the inner face of the drop link, then cut and file flush.

5. Fit the crosshead assemblies into the slide bars and locate and solder the slide bars to the cylinders. (Comet pack LC4). Note the small folded tab at the front of the slide bars should be to the top on the outer slide bar. Solder the slide bar support (18) to the top of the slide bar with the half-etched line uppermost and lined up with the outside of the slide bar. Form a curve so that the top of the strip comes just inside the edge of the running plate, then cut off any excess to ensure the loco body sits down correctly onto the chassis.
6. Assemble the return crank (9) to the eccentric rod (10) and the eccentric rod to the expansion link (11), noting that the eccentric rod is outside the return crank and the expansion link is outside the eccentric rod.
7. Fold up the motion bracket (14) as per the sketch and check that the inner expansion link supports (15) are an easy fit in their locating slots. The expansion link and the valve rod can now be fitted to the motion bracket. You will find it easier to solder the inner supports to the bracket after feeding all the components onto the 0.7mm wire.
8. Fit the lifting arms (13) to the motion bracket using 0.7mm wire passing through the rearmost holes in the inner expansion link supports. Fit the reversing linkage (21) vertically to the larger end of the outermost lifting arm on the nearside. This represents the link to the end of the reversing rod. Parts 19 and 20 are provided if you wish to replace the moulded ones on a RTR body moulding.

NOTE: Refer to the sketch for the nearside valve gear, but remember to transpose from left to right when assembling the offside gear.
9. Assemble the motion bracket to the frames, simultaneously feeding the crossheads into the slide bars. You may need to trim the end of the valve rod so that it just fits into the hole in the valve chest. Make sure the motion and cylinder assemblies are bolted securely. Place the connecting rod over the driven crankpin and fix the return crank outside this allowing a few degrees of forward lead on the return crank. Fit the trunnion covers (16) to the motion bracket.
10. Sufficient components are provided to enable the expansion link to be modelled as a 'triple sandwich' as per the prototype. If you wish to do this, bend the 'ears' on the expansion link overlays (12) through 180° as per the sketch. Feed the inner, middle and outer links onto a length of 0.7mm wire and solder top and bottom. Be careful not to solder to the wire. Bend the ends of the valve rod overlay (17) through 180° with the half-etched line to the outside of the bend. Feed the valve rod and valve rod overlay onto a length of 0.7mm wire and solder together as per the sketch. You should now find that the two forks of the valve rod fit into the corresponding slots in the expansion link, and assembly can now proceed as above.

Motion bracket / valve gear assembly sketch

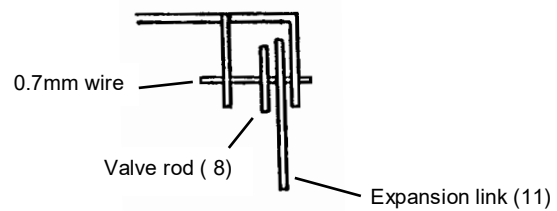
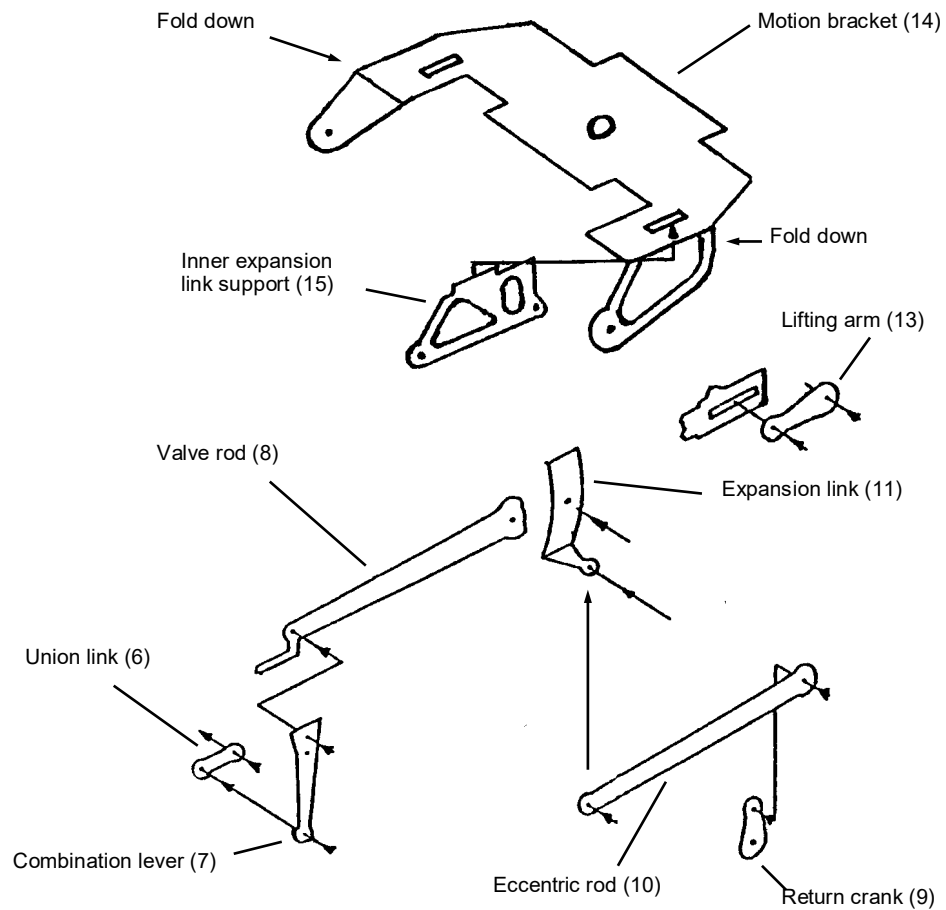

Slide bar assembly

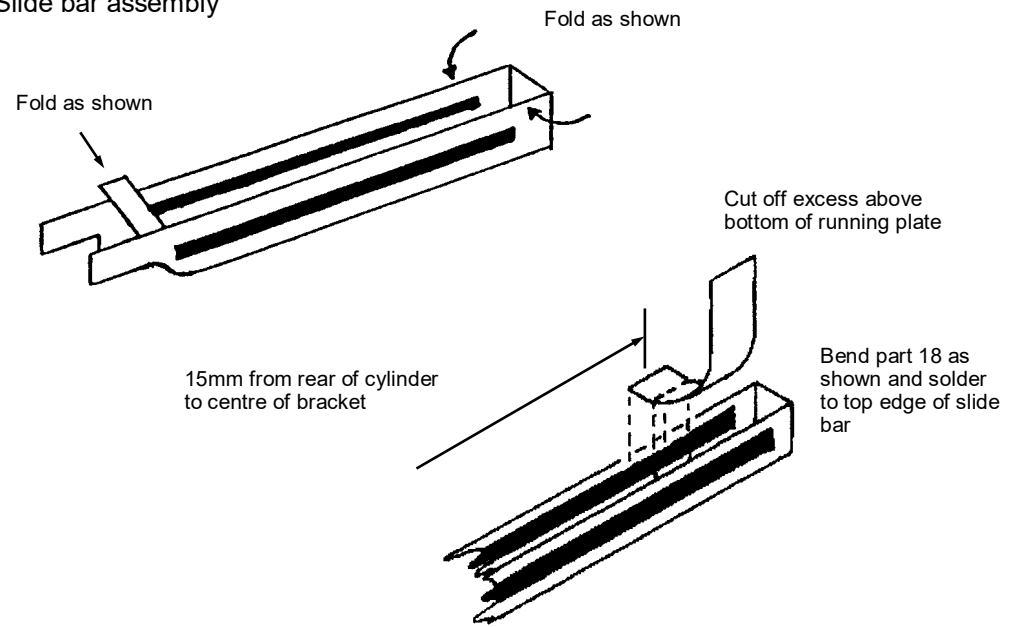

Connecting rod

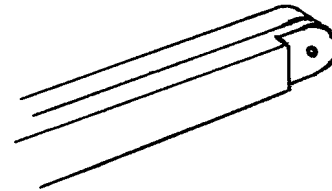

Expansion link / valve rod assembly (Section 10 only)

