



The 4mm wagon and van kit

NBRD067

North British Railway
London & North Eastern Railway

Diagram 67 (SSA 71B) Standard Cattle Wagon with Steel Underframe



Period: c1895-c1948
For 00, EM, P4 and S4

Features: white metal wagon kit, buffers with steel heads

Required to complete: split spoke wagon 12mm wheels, bearings, paint, screw couplings, transfers

The Prototype

Cattle wagons came in a variety of sizes and most companies had their own preferences. The NBR chose the medium size as their standard and were joined by the other Scottish companies and the North Eastern. In contrast the London and North Eastern preferred the long cattle wagon.

The first NBR design, to which many hundreds of vehicles were built, appeared in 1887 and a modification was made in 1892 with a slight increase in width. These earlier vehicles had wooden underframes and end stanchions with grease axle boxes. In 1893 a steel underframe wagon was produced with oil axle boxes and

steel end stanchions. Many hundreds of both designs were produced over the years. A number are known to have been Westinghouse piped. Our model depicts the later version with oil axleboxes and steel underframe designated Diagram 67.

The transport of cattle was a major source of income for the North British Railway; at Grouping over 500 cattle wagons were inherited by the LNER. Only two survived to Nationalisation; photographic evidence shows wagons awaiting scrap at Cowlairs in 1947.

References

British Goods Wagons from 1887 to the present day, R Essery, D Rowland & W Steel

Wagons on the LNER North British No1, J Hooper pp9 and 43

NBR Wagons some design aspects, G W M Sewell 36

A Pictorial Record of LNER wagons, P Tatlow p121

LNER Wagons Vol 3, P Tatlow pp111-113

Interested in the North British Railway?

North British Railway Study Group
www.nbrstudygroup.co.uk

Assembly

Please read these instructions before starting to build your model. Examine all the parts and familiarise yourself with their assembly. Remove any moulding flash (particularly from the slats on the sides) and ensure all parts fit correctly. We suggest wet fine emery paper (1200 grit) to clean up flash marks. Carry out a dummy run before assembly. Assembly is best carried out using low melt solder or an epoxy resin such as Araldite. Glues like UHU, Multibond or Thixofix can also be used. For small parts use superglue. To obtain the best results a combination of several techniques will be needed.

Cut the brass wire to form the bars on the inside of the sides. Fix the wires in the locating holes provided.

Check the fit of your chosen wheel bearings in the axleguards, drilling out if necessary. Just tack them in place for now, in case they need to be adjusted later. Fix two axleguards to one side, using the details on the solebar for alignment; the wheelbase is 36mm (9"). Now assemble the body: properly join the one end to the side with the axleguards, and tack the other end to the other side. Bring the two halves together and tack them to each other. Ensure all is level and square, and properly make the three remaining joints. Take one of the remaining axleguards and tack it to the body, trapping a wheelset in place. Ensure the wheels are firmly supported and run freely (adjust the bearings if needed – use 8BA washers as packing if they are too far apart), and that the axle is horizontal and perpendicular to the side. Do the same for the last axleguard and wheelset, ensuring that the axles are parallel to each other. When satisfied, properly fix the bearings and axleguards in place. Again, check that the wagon is level and square. If not a gentle tweak will ensure that all four wheels are in contact with a flat surface such as a glass sheet.

Cut the embossed plastic floor (transverse planks) to shape and fix it in place. Fit the buffers in place with the bolt heads at the 3, 6, 9 and 12 o'clock positions. Fix the single brake shoe to each side of the wagon followed by the brake lever.

Paint the interior as desired. Note prior to the early 1920's lime was used as a disinfectant and the wagon interior would be a white colour. After this period the interior should be a weathered wood colour. If required, add the cattle load now!

Lightly score along the embossed roof plank lines – this should cause it to form a gentle curve. Offer up the roof to the body and trim it if required. Fix it in place. Once set, cover with a sticky label or solvent weld paper on top, trimming the edges to fit.

After painting and lettering fit screw couplings.

Finishing

Clean and degrease the model, using white spirit before painting. For white metal parts use an etching primer,

such as Precision Paints PS1. The model should be painted using the livery of your choice (see over). After painting clean the model using a tissue soaked in white spirit. This is especially important if you are using dry lettering such as Powsides rather than waterslide or 'Methfix' transfers. After painting and lettering fit screw or Instantaner couplings.

Livery

North British Railway c1900-1923

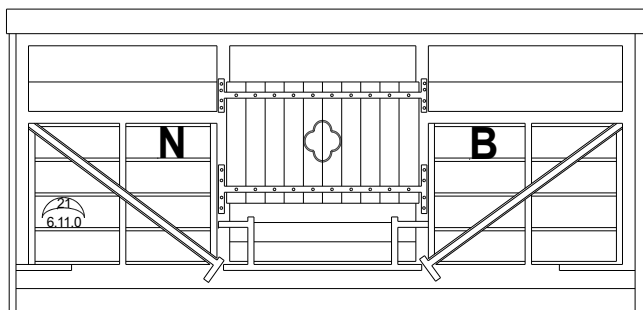

Bodywork, solebars: grey, Precision Paint P679
 Buffers, drawgear, running gear and sometimes body ironwork: black
 Insignia: white, HMRS sheet 20

London & North Eastern Railway 1923-1937

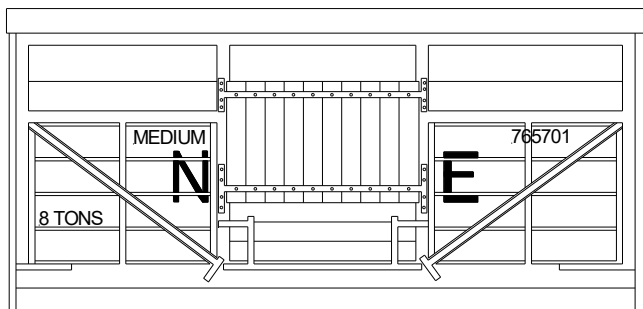

Bodywork, solebars: LNER grey, Precision Paint P66
 Underframe/brake levers: black
 Insignia: white, HMRS sheet 12, Old Time Workshop sheet 4702

London & North Eastern Railway 1937-demise

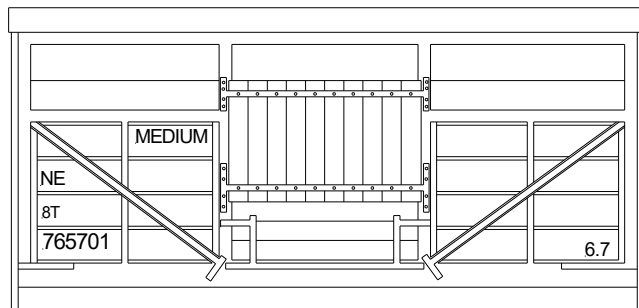

Bodywork, solebars: LNER grey, Precision Paint P66
 Underframe/brake levers: black
 Insignia: white, HMRS sheet 12, Old Time Workshop sheet 4702

It will be appreciated that many wagons would not have been repainted immediately by the LNER and would have remained in a weathered NBR livery for some time after Grouping.

Sample Numbers

65684-6/93-6, 65702/4/6/10/12/15-17/21/24/25/27/28/31/34/35/38-43/45-7/49/50/52/55/58/60/63/67 (all built 1906)
 65697, 65701/7/18/30/33/44/48/51/62 (unknown build date)
 The LNER added 700,000 to the NBR number.

Acknowledgements

51L thanks members of North British Study Group for their help in preparing this model.

A later version of these assembly instructions may be available on the Wizard Models website. For further help or information please email: info@wizardmodels.ltd

51L

51L has a wide range of locomotive, carriage and wagon kits for the following railway companies
 GWR and constituents: Cambrian Railways
 LMS and constituents: Caledonian Railway, Glasgow & South Western Railway, Highland Railway, Lancashire & Yorkshire Railway, North Staffordshire Railway
 LNER and constituents: Great Central Railway, Hull & Barnsley Railway, North British Railway, North Eastern Railway

Wizard Models

Wizard Models stocks a wide range of components and other necessities for the modeller in 00, EM and P4.

Wizard Models Limited
 PO Box 70
 Barton upon Humber
 DN18 5XY
 Tel: 01652 635885

Email: info@wizardmodels.ltd
 Shop: www.wizardmodels.ltd

Version: 6.01

Issued: July 2025

© Wizard Models Limited 2025