

## LF30 Frames for LNER Gresley A1/A3/A4 4-6-2s

Components recommended to construct a complete chassis

Motion set	LM30	Cylinders	LC4
Bogie	LS11	Crossheads	LS9
Axleboxes	LS14		
	6 off Markits	6'6", 20 spoke drivers	(WH213)
	3 axles	6 crankpins and washers	(RM2)
	2 sets	12mm bogie wheels	(WH31A)
	1 set	14mm trailing wheels	(WH33)
	Gearbox	GB5/20 and Drive Extender, or GB1/20 or GB3/20	
	Mashima	MH1628 motor	

This etch contains sideframes, 00 spacers, brake shoes and brake pull rods to produce a basic chassis of the correct scale dimensions and appearance which can be used as a substitute for a kit or RTR chassis. Cylinders, motion, crossheads and bogie to complete the chassis are all available from our range - see the panel above.

We recommend the Mashima MH1628 motor with our gearbox GB5/20 and Drive Extender for this model, and can supply the latter two together with Markits driving and bogie wheels if required. EM spacers are available separately, code LS10, as are P4, code LS60.

As supplied the frames are suitable for the Hornby A1/A3 model, and with modification to the bodyshell the Hornby and Bachmann models of the A4. It can also be adapted to fit the DJH and Wills/SE Finecast A3 and A4 kits.

### Assembly Instructions

Please note that all bends should be made with the half-etched lines to the inside and reinforced with a fillet of solder.

1. Although designed primarily as a rigid chassis, compensation systems such as Perseverance, MJT or Sharman Wheels can easily be used if the hornways are cut out at the half-etched lines before starting assembly.
2. Carefully open out the axle bearing holes in the frames until the bearings are a close fit, ensuring the bearing flanges fit snugly against the frames. This is best done using a five-sided broach. If you are using our chassis jigs (see below), DO NOT solder the bearings in place at this stage. Carefully make the vertical cuts at the cylinder cut-out position, then remove the waste metal by bending it back and forth until it fatigues off at the lower half-etched line. Also open out the holes for the brake cross-shafts to 0.75mm.
3. Select the appropriate frame spacers - their size and position will depend on the siting of the body fixings and your preferred motor/gearbox and pick-up arrangements. Our own preferences are, where possible, for a tongue and slot fixing at the front bufferbeam and a single bolt fixing under the cab, together with wiper pick-ups mounted below the chassis. A suitable layout of spacers is shown to suit this and our gearbox GB5/20 and Drive Extender and a Mashima MH1628 motor.
4. The frame spacers fold to right angles on the half-etched lines. Solder your chosen ones to one of the frames, then assemble by clamping the other side frame to the first using the wheelsets to check alignment before soldering the second sideframe. This crucial stage of the assembly can be achieved more easily and with greater accuracy by using our frame assembly jigs (code LS16 for 00, LS17 for EM and LS61 for P4). Full instructions are

provided with them.

5. With the frames assembled, solder lengths of 0.7mm wire through the brake hanger holes then thread on and solder the brake shoes in place. Their alignment is made easier if something of suitable thickness is used to space out the brake shoe from the frame, with a wheelset fitted to ensure correct spacing relative to the wheel treads.
6. Lengths of 0.7mm wire are next threaded through the bottom brake hanger holes on one side of the chassis, through both sets of brake pull rods (ensuring that they are the correct way round) and then through the second set of brake hangers. Solder the wire to the brake hangers, then slide the pull rods outwards to line up with the inner edges of the frames and solder them to the wire.
7. Finally, solder on fixing nuts for cylinders, bogie, motion bracket and pick-ups as required. The position of the fixing nut for the motion bracket is crucial, since it must line up with the hole in the bracket itself. To ensure that it does, temporarily fit the bracket in position on the frames and bolt it in place before soldering the nut to the spacer.

The chassis can now be washed to remove any flux residues, but before painting we suggest that you fit the cylinders, motion bracket and wheels and check the fit of the body. You may find some slight filing is required to obtain a perfect fit. If you next assemble the bogie then the frames and bogie can be painted together and left to harden whilst the motion is assembled.

Our preference is for wiper pick-ups made from 26swg phosphor bronze wire as per the sketch. The wire is soldered to PCB strip which is bolted to a frame spacer. We recommend that, if possible, you arrange the pick-up to be "bolt on" since this allows for easy removal and adjustment of the wire wipers. Pack LS23 provides the necessary parts.

Sketch 1 Showing arrangement of spacers, using a Mashima MH1628, GB5/20 and Drive Extender

- Spacer A 10mm x 10mm
- Spacer B 10mm x 6mm
- Spacer C 6mm x 6mm
- Spacer D 6mm x 3mm

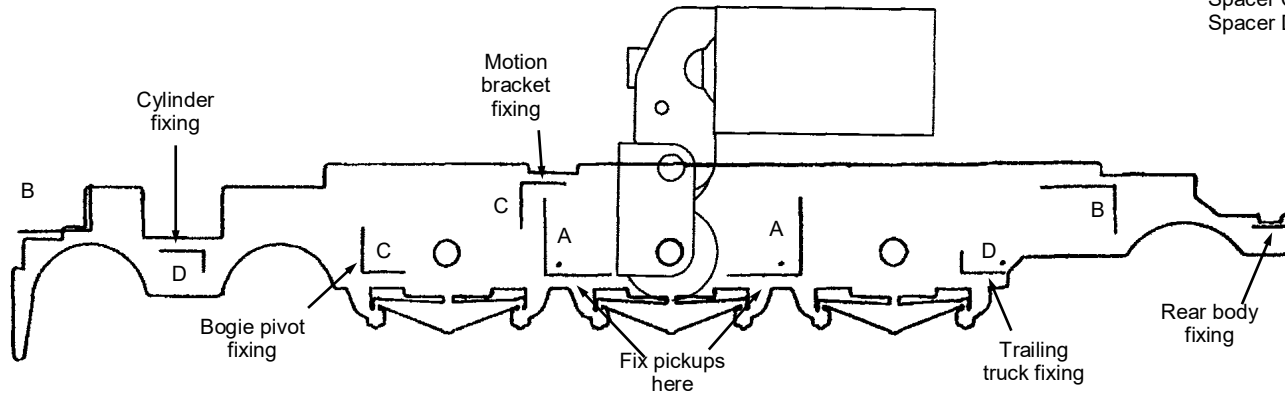

Sketch 5 Suggested pick up arrangement

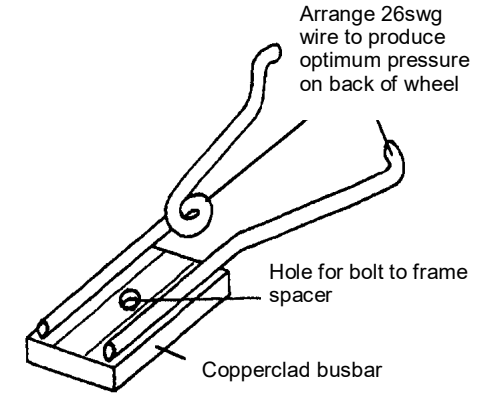

Sketch 2 Showing arrangement of spacers, using a Mashima MH1628 and GB1 or GB3

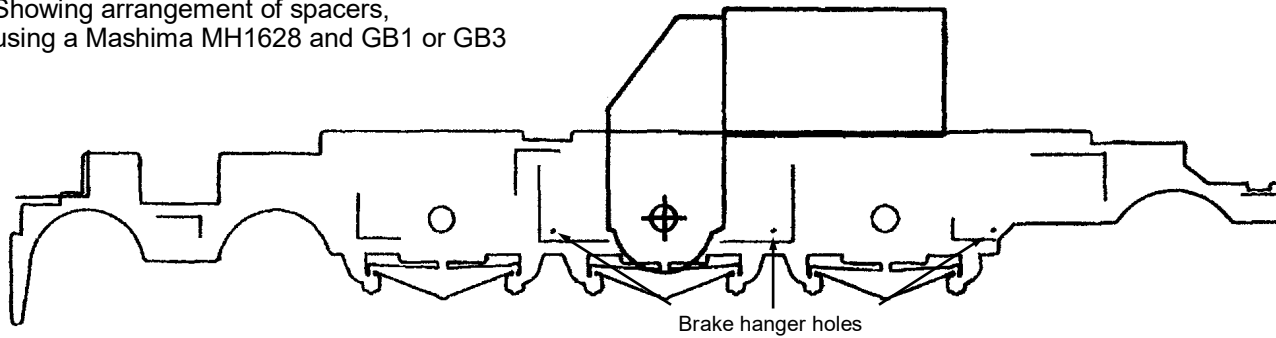

We can supply a pickup set comprising wide track pcb, phosphor bronze wire, fixing nuts and bolts and insulated wire (code LS23).

For tender locos a second pickup set can be used in the tender and the current fed to the locomotive using our loco-tender pack (code LS24).

Sketch 3 Exploded view showing rear frame assembly

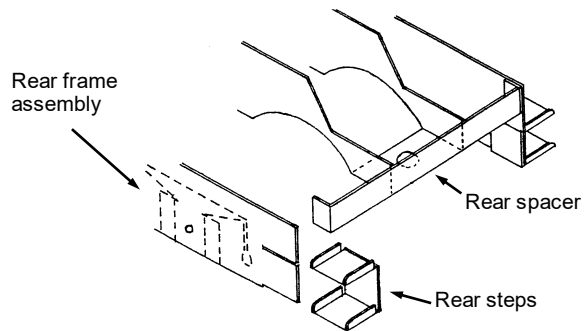

Sketch 4 Showing rear frame extension shape



Sketch 6 Suggested front body fixing

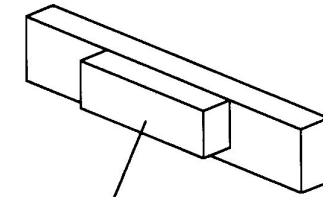

Add a packing piece 10mm x 4mm of 40thou plasticard to back of bufferbeam to create a slot here. Ensure the bottom of the plasticard is flush with the bottom of the bufferbeam.