

## S2B BR(S) BULLEID OPEN THIRD (TO then SO)

D2017

D2017: 45 built 1950-1951; withdrawn 1965-1970; 4 preserved

64'6"

These etched sides can be built into a complete coach using products from our range as supplied in our full kits. Please refer to the panel opposite. Should you prefer they can also be used to overlay the Bachmann Bulleid coaches, or as a basis for a scratchbuilt coach.

These carriages were in service all over the Southern Region. They mostly operated as loose coaches and were marshalled into ocean liner boat trains, special or relief workings as required. Some were in 8 coach sets as shown below. In 1965 22 were transferred and shared equally between the Eastern and Scottish Regions.

The first batch of D2017 had side fairings and 10" deep window vents, so cannot easily be represented by this etch.

### Sample formations

Ocean Liner 8 coach sets	350-352	BCK/TO/TO/FK/TO/TO/TO/BCK
	353	BCK/TO/TO/TO/TO/FK/FK/BCK
	354	BCK/TO/TO/TO/TO/FK/FK/BFK

The FKs in the above sets are Comet code S1; the BCKs are Maunsell stock and the BFKs Ironclad stock.

### Running numbers

S1462S-S1500S	built 1950	1467/1502 and 1468/95/75 to set 351
S1501S-S1506S	built 1951	1486/96/99/81 to set 353
1476/7 and 1478-80 to set 350		
1469/1501 and 1498/85/91 to set 352		
1463/72/1503/4 to set 354		

### Livery

Coaches in sets 80-94 were painted late SR malachite green but without class numerals. The numbers were in Southern 'Sunshine Yellow' style and position and were prefixed 'S'. The remaining corridor coaches and all of the open coaches were painted in BR carmine and cream. From 1956 they were repainted BR SR stock green. It is on record that at least one of the Scottish transfers (Sc1466S) was painted BR maroon. In general the ends, underframe and bogies were black and the roof grey.

### Further information

An Illustrated History of Southern Coaches	Mike King	OPC
Bulleid Coaches in 4mm scale	S W Stevens Stratten	MRC Planbook 1
Bulleid's SR Steam Passenger Stock	David Gould	Oakwood Press
British Railways Pre-Nationalisation Coaching Stock Vol. 2	H Longworth	O.P.C.

Our thanks to David Gentle for his help and encouragement in the preparation of this information

COMET MODELS components required to complete this carriage are:

Underframe	US1	Bogies	BS1
Underframe castings	UCS1	End castings	ECS1
Ends	ES1	Roof castings	RC1
Roof	C10	Interior	INT4
Mushroom vents	RC6	Regulator box	C36

### Scrap views showing additional detailing of sides and ends

(not all details may apply to this diagram)

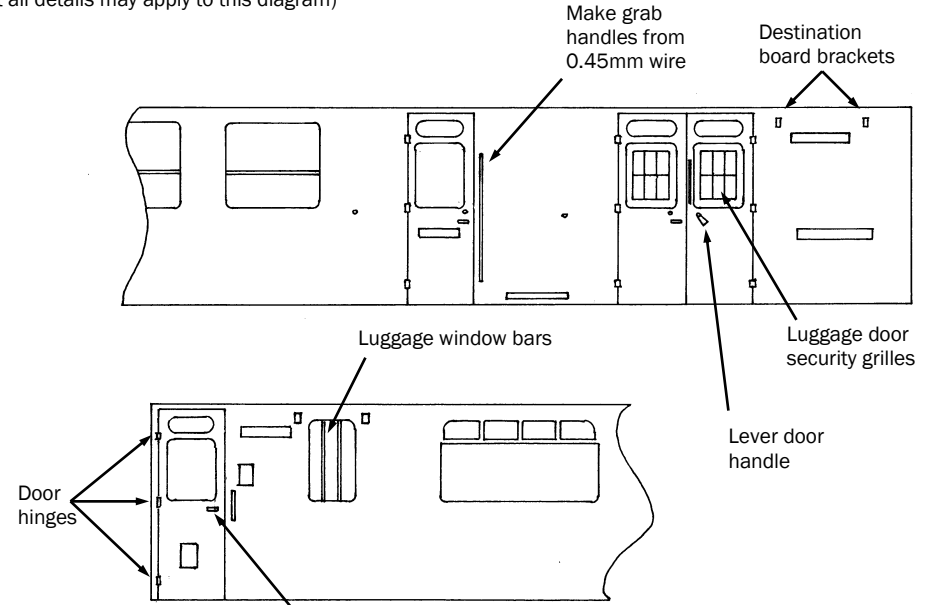

Door hinges are available in product C26

'T' door handles are supplied in complete kits and are available in product C6

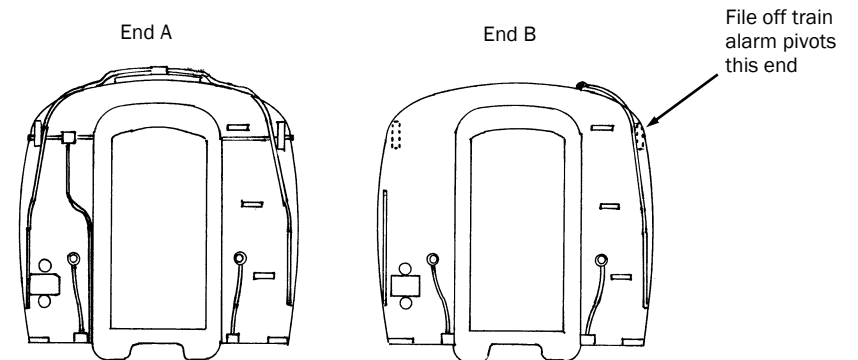

D2017

