

TF4 Tender Outside Frames Kit LMS Fowler 6'6" x 6'6" Wheelbase

Parts list

Etchings

- | | |
|-----------------------------------|-----------------------|
| 1. Tender base | 6. Dragbeam overlay |
| 2. Outer frames (2) | 7. Bufferbeam overlay |
| 2a. Riveted overlay (2) | 8. Coupling hook |
| 3. Front steps/dragbeam | 9. Water scoop base |
| 4. Rear steps/bufferbeam | 10. Drawbar pocket |
| 5. Front and rear step treads (4) | 11. Drawbar (2) |

Castings

- | | |
|---------------------|-------------|
| Axlebox/springs (6) | Steam pipe |
| Buffers (2) | Water scoop |
| Vacuum pipe | |

Assembly instructions

- Press out the rivet detail from the back of the outer frames (2) and solder the riveted overlay strip (2a) along the top edge of the frames. File down the overlay at the front and rear to match the rebates in the top edge of the frames.
- Fit the tabs on the outer frames into the inner slots of the tender base (1) and tack solder to the base at the centre. Make sure the frames are the correct way round - to help you, both frames and base are marked front (F) and rear (R).
- Fold up the front and rear step units (3) and (4) as per the sketch, then curve up the outer edges of the intermediate step treads (5), and solder them into their locating slots.
- Locate front and rear step units in place, noting that the projecting tabs on the frames engage in the slots in the dragbeam and bufferbeam of the step units, and tack solder in place.
- Carefully check the alignment of frames and steps, adjusting if necessary, and when satisfied make good all joints with solder.
- File back the projecting frame tabs flush with the dragbeam and bufferbeam, then add the dragbeam and bufferbeam overlays (6 and 7). Note that the mounting lugs for the steam and vacuum pipes should be on each side of the coupling hook, rather than lining up on the same side.

- Solder 8BA nuts on TOP of the tender base for the front and rear chassis fixing screws.

If you are assembling the tender body from one of our kits we suggest you now proceed with this before final detailing.

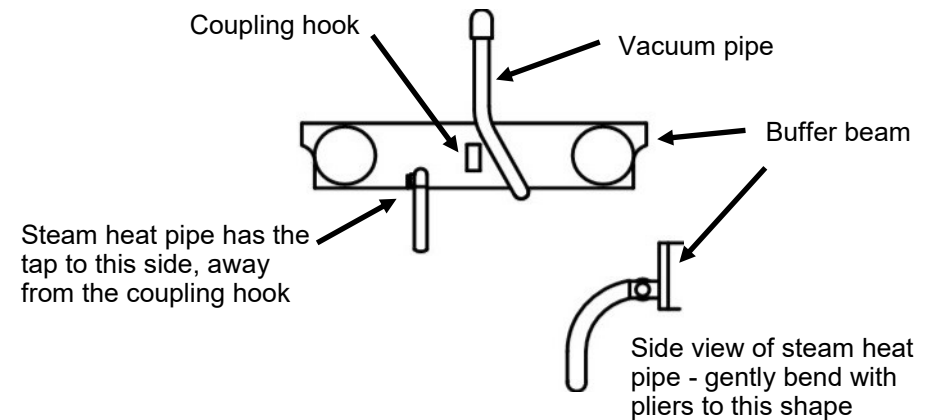

- Add coupling hook (8), steam and vacuum pipes, buffers and axlebox/spring units. Note the vacuum pipe is to the right of the coupling hook and passes through the slot in the tender base. It is also cranked towards the centre line of the tender but straightens to vertical after it emerges from the slot in the tender base. The steam heat pipe has the tap on the side away from the coupling hook and is bent down gently with pliers as shown.
- Bend up the drawbar pocket (10) and solder to the front spacer of the tender chassis so that the slots in both the spacer and the pocket line up.
- Fold up the water scoop base as shown and fit to the tender chassis simultaneously with the centre brake hanger - the brake hanger wire passing through the holes in the end tabs. The water scoop fits into the hole at the other end of the base, making sure there is enough clearance between the bottom of the scoop and the track. Additional detail of the scoop linkage can be added if you really must.
- Solder the two halves of the drawbar (11) together to give sufficient clearance between loco and tender on your tightest curves. The drawbar fixing is made via the front chassis fixing bolt as per the sketch.

